



NORTH ROOM
201-210

PORTE TAGLIAFUOCO IN ACCIAIO
STEEL FIRE DOORS

NEW IDRA

El₂ 60/120

Dierre
YOUR HOME, YOUR LIFE

7	PORTA PER ESTERNI MARCATA "CE" SECONDO EN 16034 <i>"CE" MARKED EXTERNAL DOOR FOLLOWING EN 16034</i>
9	PORTA PER INTERNI OMOLOGATA TAGLIAFUOCO <i>INTERNAL FIRE-RATED DOOR</i>
11	NEW IDRA
14	PERFORMANCE E CARATTERISTICHE TECNICHE, IN DETTAGLIO <i>PERFORMANCE AND SPECIFICATIONS, IN DETAIL</i>
18	OPTIONAL
19	SOLUZIONI DI FISSAGGIO <i>FITTING SOLUTIONS</i>
20	INGOMBRI IN APERTURA <i>OPENING OVERALL DIMENSIONS</i>
24	LE FINESTRATURE <i>THE GLAZING</i>
25	SOPRALUCE E FIANCHILUCE <i>FANLIGHTS AND SIDE LIGHTS</i>
26	FINITURE MANIGLIONI NO PANIC <i>HANDLES NO PANIC FINISH</i>
27	SCHEDE TECNICHE <i>TECHNICAL SHEETS</i>
46	TAVOLA SINOTTICA <i>SYNOPTIC TABLE</i>



New Idra EI₂ 60 un battente in acciaio inox
New Idra EI₂ 60 stainless steel single leaf



New Idra EI₂ 120 un battente laccato grigio
New Idra EI₂ 120 single leaf lacquered gray



New Idra EI₂ 120 doppio battente laccato RAL 3020
New Idra EI₂ 120 double leaf lacquered RAL 3020

PORTA PER ESTERNI MARCATATA "CE" SECONDO EN 16034

La porta a battente **New Idra** può essere marcata CE secondo le norme di prodotto **EN 14351-1** e **EN 16034**. Per poter ottenere tali marcature è necessario sottoporre il processo produttivo ed il prodotto stesso a specifici iter e controlli che garantiscano il fatto che tutta la fase produttiva avvenga nelle modalità e con i componenti descritti nei vari documenti di prova.

La norma di prodotto EN 16034 dal titolo "Porte pedonali, porte industriali, commerciali, da garage e finestre apribili - Norma di prodotto, caratteristiche prestazionali - Caratteristiche di resistenza al fuoco e/o controllo del fumo" rappresenta un caso anomalo di quanto finora esistente a livello prodotti da costruzione, è infatti una norma che prevede la marcatura CE come scopo ma che non può vivere di vita propria. Per essere più chiari, questa norma non può essere applicata ad un prodotto se questo non è già marcato CE a seguito applicazione della norma di prodotto specifica del prodotto stesso. Quindi si può dire che la EN 16034 è una norma che porta ad una marcatura "secondaria" che deve obbligatoriamente viaggiare in parallelo con una marcatura "principale".

La norma di prodotto per la marcatura "principale" attualmente in vigore per le porte New Idra è la: EN 14351-1 dal titolo "Finestre e porte - Norma di prodotto, caratteristiche prestazionali - Parte 1: Finestre e porte esterne pedonali". Manca all'appello una norma "principale" molto importante che è la EN 14351-2 dal titolo "Finestre e porte - Norma di prodotto, caratteristiche prestazionali - Parte 2: Finestre e porte interne pedonali". La mancanza di questa norma genera non poca confusione sul mercato per quanto riguarda le porte a battente. Infatti le porte interne allo stato attuale non possono essere marcate CE secondo la EN 16034 (marcatura secondaria) in quanto non può essere applicata una marcatura "principale".

Alla marcatura CE secondo la EN 16034 per prodotti tagliafuoco sono legate tutta una serie di norme definite EXAP che permettono estensioni di vario genere sul prodotto a fronte di prove al fuoco effettuate secondo la EN 1634-1. La marcatura CE su questo tipo di prodotti è obbligatoria dal 1/11/19, da tale data è quindi obbligatorio fornire l'unico documento che accompagna la marcatura: la DoP (dichiarazione di prestazioni). Sul prodotto deve essere apposta un'etichetta che renda rintracciabile il prodotto, non è obbligatoria la targhetta metallica che però viene comunque applicata sul prodotto per garantire un'identificazione nel tempo.

Il prodotto New Idra è classificato da **El:60** a **El:120** nelle varie configurazioni presenti a listino e a catalogo, per maggiori dettagli rivolgeti ad un rivenditore ufficiale Dierre.

"CE" MARKED EXTERNAL DOOR FOLLOWING EN 16034

The New Idra hinged door can be CE marked according to EN 14351-1 and EN 16034 product standards. In order to obtain these markings, it is necessary for the production process and the product itself to undergo specific processes and checks that ensure the whole production phase takes place following the methods and with the components described in the various test documents.

The EN 16034 product standard named "Pedestrian doorsets, industrial, commercial, garage doors and openable windows - Product standard, performance characteristics - Fire resisting and/or smoke control characteristics" represents an odd case regarding existing regulations concerning building products, it is in fact a standard foreseeing for CE marking as a purpose but that cannot stand alone.

To be clearer, this standard cannot be applied to a product if it is not already CE-marked as a result of the product-specific product standard. So it can be said that EN 16034 standard is a standard that leads to a "secondary" marking that must necessarily go together with a "main" marking. The currently in force product standard for the "main" marking for New Idra doors is: EN 14351-1 named "Windows and doors - Product standard, performance characteristics - Part 1: Windows and external pedestrian doorsets". There is no relevant "main" standard that is EN 14351-2 named "Windows and doors - Product standard, performance characteristics - Part 2: Internal pedestrian doorsets". The lack of this standard generates a lot of confusion on the market with regard to swing doors. In fact, internal doors cannot currently be CE marked according to EN 16034 (secondary marking) because a "main" marking cannot be applied.

The CE marking according to EN 16034 for fire-rated products is linked to a whole series of rules defined as EXAP that allow various kinds of extensions on the product having fire tests carried out according to EN 1634-1.

The CE marking on this type of product has been mandatory since 1/11/19, so from that date it is mandatory to provide the only document that accompanies the marking: the DoP (declaration of performance). A label must be placed on the product to make it traceable, the metal tag is not mandatory, but it is still applied on the product to ensure identification over time. The New Idra product is classified from **El:60** to **El:120** in the various configurations on the price list and in the catalogue, for more details please contact a Dierre official retailer.

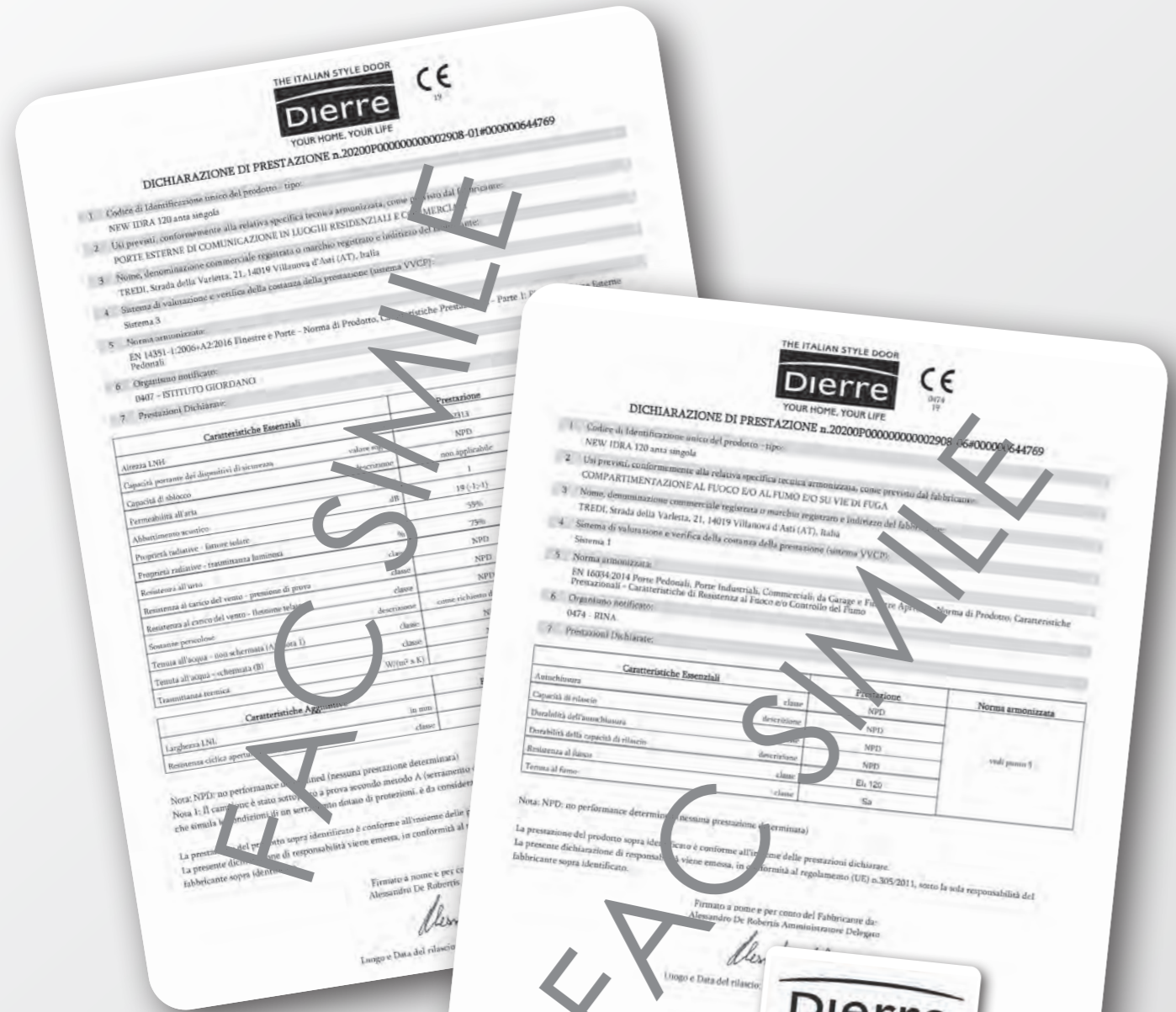

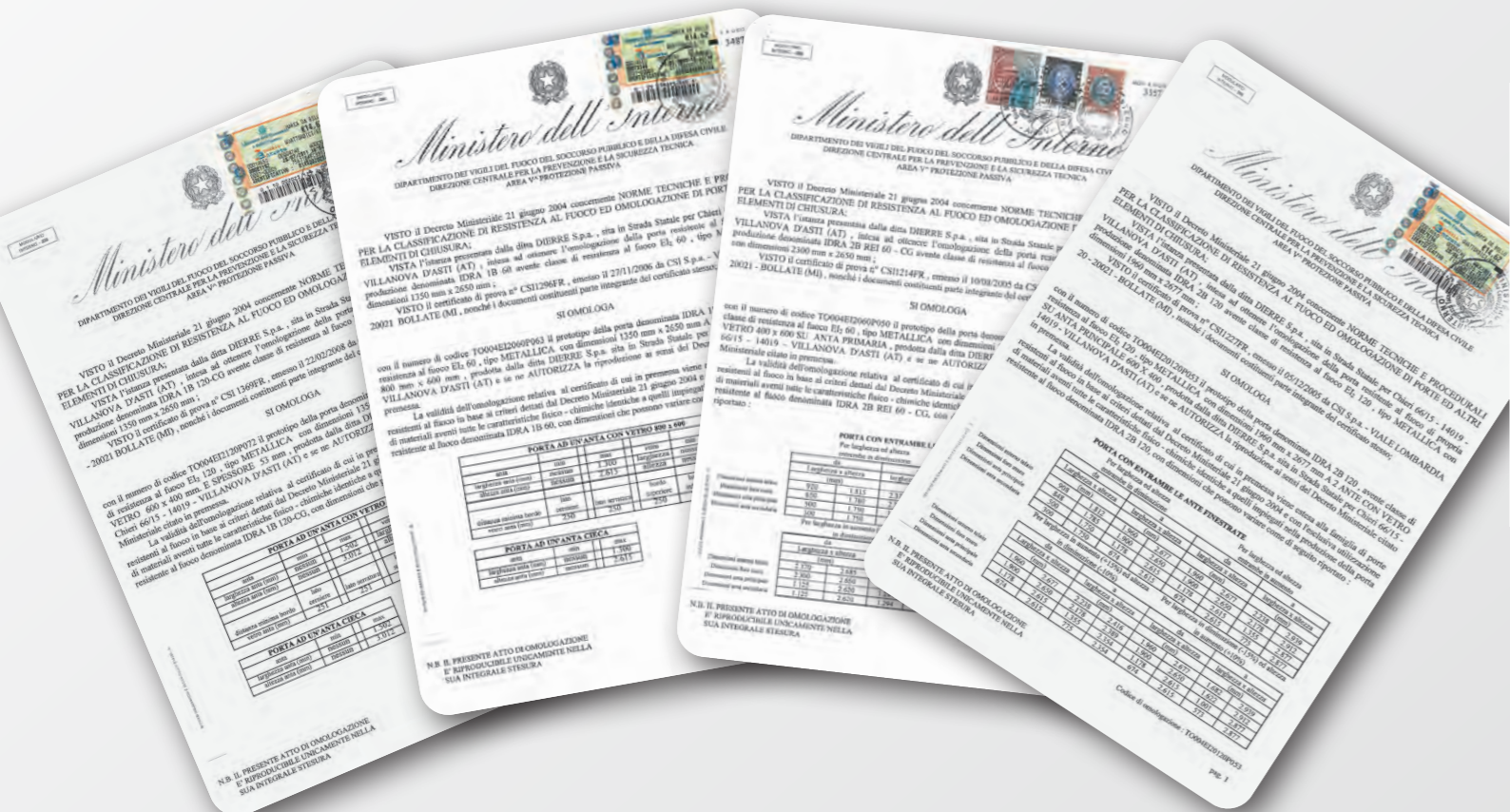

PORTA PER INTERNI OMOLOGATA TAGLIAFUOCO

New Idra è certificata e omologata per la resistenza al fuoco secondo la norma europea EN 1634-1, rilasciata in seguito a test specifici che garantiscono la conformità ai rigorosi standard.

Classificazione EI. Il termine "EI" sigla la capacità di un prodotto di conservare, di fronte all'attacco del fuoco, alcune caratteristiche per un tempo stabilito. Ogni lettera si riferisce a una diversa caratteristica.

La E indica la tenuta, quindi non produrre né lasciare passare fiamme.

La I sta per isolamento termico, cioè la capacità di ridurre la trasmissione del calore. Di conseguenza, si definisce "E" una porta che conserva la propria stabilità ed è in grado di bloccare le fiamme e "EI" un prodotto che, oltre alle qualità precedenti, limita la trasmissione del calore fino a un massimo di 180°C sul lato non a contatto diretto con il fuoco (ovvero lato freddo).

Per ogni prodotto e accessorio, la validità della classificazione nei diversi paesi europei è soggetta a verifica presso l'ufficio tecnico Dierre.

INTERNAL FIRE-RATED DOOR

New Idra is certified and approved for fire resistance according to the European EN 1634-1 standard, issued following specific tests that ensure compliance to strict standards.

EI Classification. The term "EI" means the ability of a product to preserve, in the event of fire attack, certain characteristics for a set time. Each letter refers to a different characteristic. E indicates the seal, so not producing or letting flames pass through. I stands for thermal insulation, that is, the ability to reduce heat transmission. As a result, "E" is a door that maintains its stability and is able to block flames and "EI" is a product that, in addition to the previous features, limits the transmission of heat up to a maximum of 180 degrees C on the side not in direct contact with the fire (i.e. cold side). For each product and accessory, the validity of the classification in the different European countries is subject to the Dierre technical office verification.



NEW IDRA

New Idra è una porta tagliafuoco flessibile e sicura, che risponde alle esigenze di compartimentazione di abitazioni, supermercati, ospedali, magazzini, locali macchine, cinema, ristoranti e qualsiasi altro edificio pubblico. Idonea a varchi di medie dimensioni tipiche di porte a 1 e 2 battenti, New Idra combina in un giusto equilibrio differenti caratteristiche, che la rendono una delle chiusure tagliafuoco più diffuse. Grazie alla facilità di posa, senza forature aggiuntive o scantonature nel muro, si adatta ad ogni spazio con estrema versatilità. La complanarità al profilo del telaio, le zanche prestampate nel telaio stesso e la chiusura con 3 cerniere garantiscono massima funzionalità. Inoltre, è disponibile in una vasta gamma di colori e dimensioni, sia standard che fuori misura, in versione cieca, con la robustezza tipica dell'acciaio, e nella versione vetrata, con differenti opzioni di finestrature. New Idra è disponibile anche in versione antipanico o con maniglia/maniglia e protezione superficiale, con pellicola da asportare dopo la posa.

New Idra is a flexible and safe fire door, that meets the protection needs of houses, supermarkets, hospitals, warehouses, machine rooms, theatres, restaurants and any other public building. Suitable for medium size openings, typical of single or double leaf doors, New Idra is the ideal balance of different features, that make it one of the most popular fire doors. They can be installed easily, without additional drilling or alterations to the wall structure, with great versatility suits any environment. The profile flush to the frame, the ties embedded in the frame, and a 3-hinge closure guarantee the highest performances.

We also offer a wide range of colours and sizes, both standard and special sizes; in the blank version, with the typical sturdiness of steel, and in the glazed version, with different glazing options available. New Idra is also available in the panic exit version or with handle/handle and surface protection, with a film that can be removed after fitting.



New Idra EI₂ 120 doppio battente laccato RAL 7037
New Idra EI₂ 120 double leaf lacquered RAL 7037

PERFORMANCE E CARATTERISTICHE TECNICHE, IN DETTAGLIO

PERFORMANCE AND SPECIFICATIONS, IN DETAIL

Struttura del telaio rigida con zanche
Rigid frame structure with ties



Complanarità tra telaio e anta
Complanarity between frame and leaf

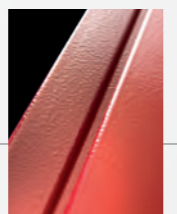

I battenti e i telai sono di serie zincati con la finitura avorio chiaro o RAL 9010. Opzionalmente sono disponibili le finiture RAL per esterni o in acciaio inox.
Standard leaves and frames are zinc-coated and come in light ivory or RAL 9010 finishing. RAL exterior or stainless steel finishings are available upon request.

Di serie le porte New Idra sono fornite con la serratura antincendio, inserto patent con chiavi in dotazione e coppia di maniglie antinfortunistiche in resina nera. Opzionalmente si possono abbinare alla porta maniglioni antipanico, manigliera in acciaio inox, cilindri cifrati, serrature a 3 punti di chiusura.
New Idra doors come with the following standard features: fire-resistant lock, Patent insert complete with keys and two accident-prevention handles in black epoxy. Stainless steel handles, encrypted cylinders, 3-lock points locks can be combined to the panic exit bars.



Per il controllo accessi è possibile montare lo sblocco elettrico.
Electric unlock can be mounted for access monitoring.

All'interno delle ante, sul lato a spingere, viene montato sempre un rinforzo, per migliorare la struttura della porta in caso del montaggio del maniglione anche in un secondo tempo.
A reinforcement is always fitted inside the leaves, on the push side, in order to improve the door structure in case a panic exit bar is fitted or retro-fitted.

Le porte New Idra Elz 60 possono essere dotate di soglia mobile.
New Idra doors Elz 60 can be fitted with mobile threshold.

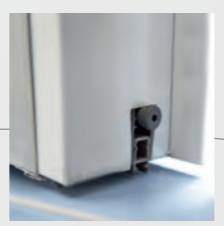

Tutte le porte tagliafuoco, di serie, sono dotate di un sistema di autochiusura. Per migliorare l'uso della porta si può dotare la porta di chiudiporta, che possono essere con braccio a V, a slitta, o incassati nell'anta.
All fire doors come with a standard self-closure system. In order to improve ease of use, the door can be equipped with V-boom, sliding or leaf-enclosed door closers.



All'interno delle ante, sul lato a tirare, viene montato sempre un rinforzo, per migliorare la struttura della porta in caso del montaggio del chiudiporta anche in un secondo tempo.
A reinforcement is always fitted inside the doors, on the pull-side, in order to improve the structure of the door in case of a door closer is fitted or retro-fitted.

Le porte New Idra possono essere corredate di finestrature ad oblò o rettangolari, di varie misure. Inoltre, su richiesta del cliente, è possibile spostarle dalla posizione standard.
New Idra doors can be fitted with round or square glazing, in several sizes. They can also be moved from their standard position upon request.

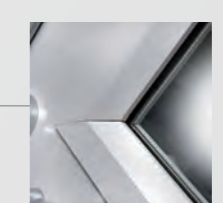

Le porte New Idra Elz 60 possono essere dotate di griglie d'aerazione di varie misure.
New Idra doors Elz 60 can be fitted ventilation grilles in several sizes.



Le cerniere in dotazione alle porte tagliafuoco permettono una regolazione, anche a posteriori, della anta per compensare le imperfezioni murarie e d'installazione.
The hinges provided with the fire doors also allow to perform a future set-up of the door to compensate possible wall and installation imperfections.



PERFORMANCE E CARATTERISTICHE TECNICHE, IN DETTAGLIO

PERFORMANCE AND SPECIFICATIONS, IN DETAIL

Struttura del telaio rigida con zanche
Rigid frame structure with ties



I battenti e i telai sono di serie zincati con la finitura avorio chiaro o RAL 9010. Opzionalmente sono disponibili le finiture RAL per esterni o in acciaio inox.
Standard leaves and frames are zinc-coated and come in light ivory or RAL 9010 finishing. RAL exterior or stainless steel finishings are available upon request.

Complanarità tra telaio e anta
Complanarity between frame and leaf



Di serie le porte New Idra sono fornite con la serratura antincendio, inserto patent con chiavi in dotazione e coppia di maniglie antinfortunistiche in resina nera. Opzionalmente si possono abbinare alla porta maniglioni antipanico, maniglieria in acciaio inox, cilindri cifrati, serrature a 3 punti di chiusura.
New Idra doors come with the following standard features: fire-resistant lock, Patent insert complete with keys and two accident-prevention handles in black epoxy. Stainless steel handles, encrypted cylinders, 3-lock points locks can be combined to the panic exit bars.

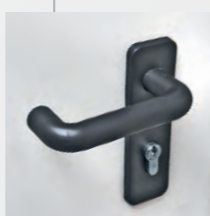

Per il controllo accessi è possibile montare lo sblocco elettrico.
Electric unlock can be mounted for access monitoring.

All'interno delle ante, sul lato a spingere, viene montato sempre un rinforzo, per migliorare la struttura della porta in caso del montaggio del maniglione anche in un secondo tempo.
A reinforcement is always fitted inside the leaves, on the push side, in order to improve the door structure in case a panic exit bar is fitted or retro-fitted.



Le porte New Idra El2 60 possono essere dotate di soglia mobile.
New Idra doors El2 60 can be fitted with mobile threshold.

Selettore di chiusura
Closure selector

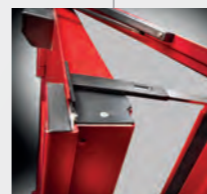

Tutte le porte tagliafuoco, di serie, sono dotate di un sistema di autochiusura. Per migliorare l'uso della porta si può dotare la porta di chiudiporta, che possono essere con braccio a V o a slitta.
All fire doors come with a standard self-closure system. In order to improve ease of use, the door can be equipped with V-boom, sliding or leaf-enclosed door closers.

All'interno delle ante, sul lato a tirare, viene montato sempre un rinforzo, per migliorare la struttura della porta in caso del montaggio del chiudiporta anche in un secondo tempo.
A reinforcement is always fitted inside the doors, on the pull-side, in order to improve the structure of the door in case of a door closer is fitted or retro-fitted.

Le porte New Idra possono essere corredate di finestrate ad oblò o rettangolari, di varie misure. Inoltre, su richiesta del cliente, è possibile spostarle dalla posizione standard.
New Idra doors can be fitted with round or square glazing, in several sizes. They can also be moved from their standard position upon request.

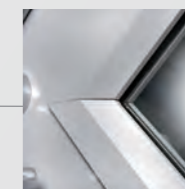

Le porte New Idra El, 60 possono essere dotate di griglie d'aerazione di varie misure.
New Idra doors El, 60 can be fitted ventilation grilles in several sizes.

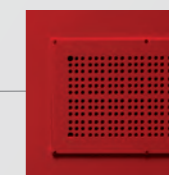

Le cerniere in dotazione alle porte tagliafuoco permettono una regolazione, anche a posteriori, della anta per compensare le imperfezioni murarie e d'installazione.
The hinges provided with the fire doors also allow to perform a future set-up of the door to compensate possible wall and installation imperfections.



EXTRA PIÙ COMUNI

POPULAR EXTRAS

SOLUZIONI DI FISSAGGIO

FITTING SOLUTIONS

EXTRA IN BASE ALLA TIPOLOGIA DI MURATURA

Installazione con zanche a murare (di serie)
 Installazione con tasselli
 Installazione con controtelaio
 Installazione su mazzetta
 Installazione su pareti
 in cartongesso E_l 60 e E_l 120

EXTRA PER ESIGENZE DI SICUREZZA

Porte per uscite antipanico
 Porte per uscite d'emergenza
 Porte a 3 punti di chiusura
 Porte normalmente aperte

EXTRA PER ESIGENZE D'IMPIEGO

Finestratura
 Chiudiporta
 Fascioni/zoccoli paracolpi
 Imbotti
 Porte con sopra luce e fiancoluci
 Porte in acciaio inox

EXTRA PER CONTROLLO ACCESSI

Sblocco elettrico
 Serrature elettriche
 Elettromaniglia
 Elettroblocco magnetico

EXTRA PER ESIGENZE ESTETICHE

Personalizzazione delle porte grazie
 all'ampia gamma di finiture RAL

EXTRA PER ELEVATE ESIGENZE PRESTAZIONALI

Abbattimenti acustici
 Tenuta aria/vento
 Antieffrazione

EXTRAS BASED ON THE WALL TYPE

Installation with wall ties (standard)
 Installation with bolts
 Installation with subframe
 Installation on reveal
 Plasterboard wall installation
 E_l 60 and E_l 120

EXTRAS FOR SAFETY REQUIREMENTS

Panic exit doors
 Emergency exit doors
 3-lock points doors
 Normally open doors

EXTRAS FOR USAGE REQUIREMENTS

Grazing
 Door closer
 Bumper bands/skirting
 Cornices
 Doors with fanlights and side lights
 Stainless steel doors

ACCESS CONTROL EXTRAS

Electric release
 Electric locks
 Electrohandle
 Magnetic electric block

AESTHETIC EXTRAS

Door customisation thanks to the
 wide range of RAL finishings

EXTRAS FOR HIGH-PERFORMANCE NEEDS

Noise reduction
 Air/wind tightness
 Burglar resistance

TELAIO A MURARE
BRICK-IN FRAME

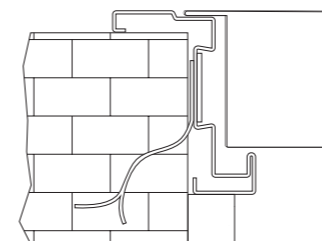

TELAIO SU CONTROTELAIO
FRAME ON SUBFRAME

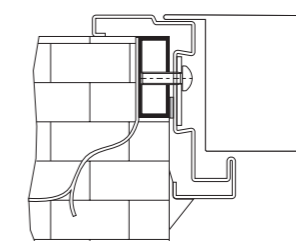

TELAIO SU CONTROTELAIO
(solo PORTA FIREWALL)
FRAME ON SUBFRAME
(FIREWALL ONLY)

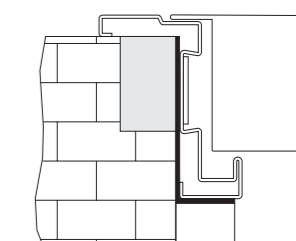

TELAIO A TASSELLARE
BOLT-IN FRAME

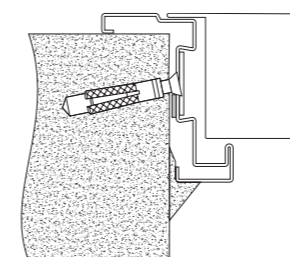

TELAIO SU MAZZETTA
Tipo VISUAL CON PROFILO A "L"
FRAME ON REVEAL
VISUAL TYPE WITH "L" SHAPED PROFILE

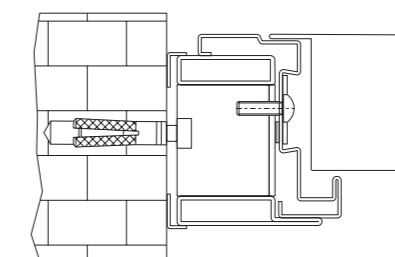

TELAIO SU MAZZETTA
Tipo VISUAL CON PROFILO A "T"
FRAME ON REVEAL
VISUAL TYPE WITH "T" SHAPED PROFILE

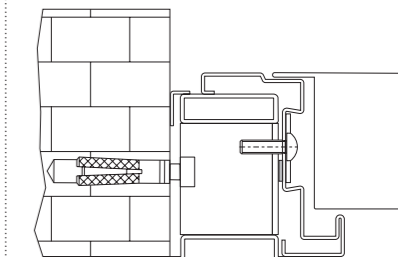

MONTAGGIO SU
PARETE IN CARTONGESSO E_l 60
E_l 60 PLASTERBOARD
WALL MOUNT

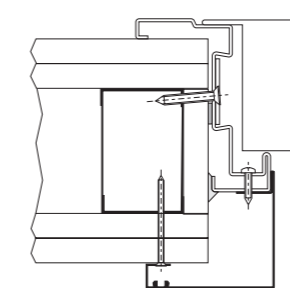

L'imbotte non è necessario
 con la marcatura CE
 The padding is not necessary
 with the CE marking

MONTAGGIO SU
PARETE IN CARTONGESSO E_l 120
E_l 120 PLASTERBOARD
WALL MOUNT

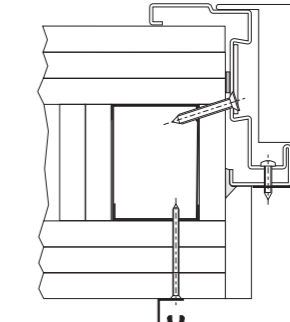

L'imbotte non è necessario
 con la marcatura CE
 The padding is not necessary
 with the CE marking

INGOMBRI IN APERTURA

OPENING OVERALL DIMENSIONS

NEW IDRA 1 BATTENTE EI₂ 60/120
 NEW IDRA SINGLE LEAF EI₂ 60/120

NEW IDRA 2 BATTENTI EI₂ 60/120
 NEW IDRA DOUBLE LEAF EI₂ 60/120

INGOMBRI PORTA CON APERTURA A 90°
 OPENING OVERALL DIMENSIONS WITH A 90° OPENING ANGLE

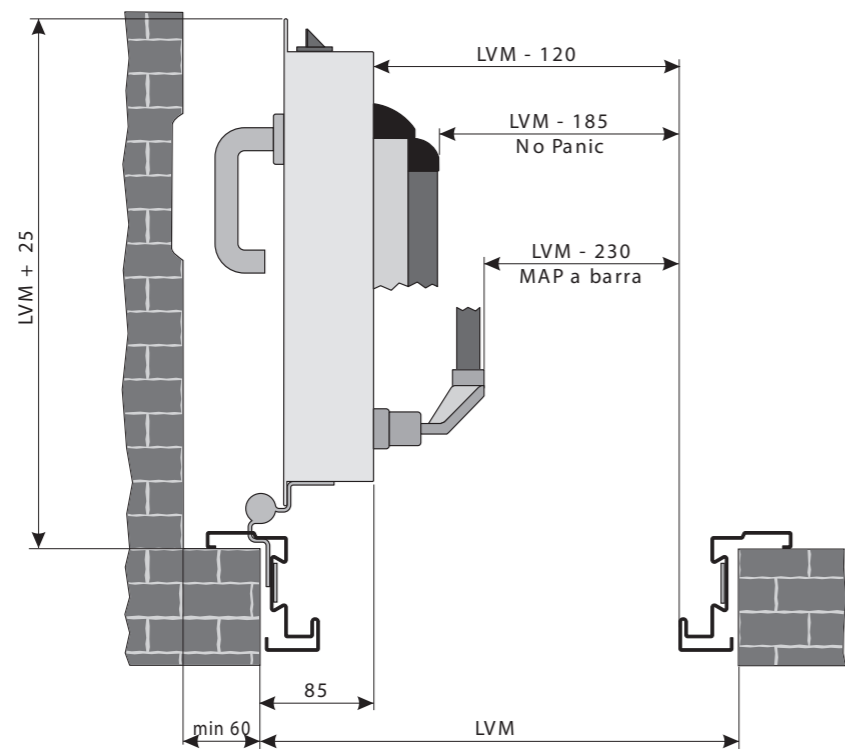

INGOMBRI PORTA CON APERTURA A 90°
 OPENING OVERALL DIMENSIONS WITH A 90° OPENING ANGLE

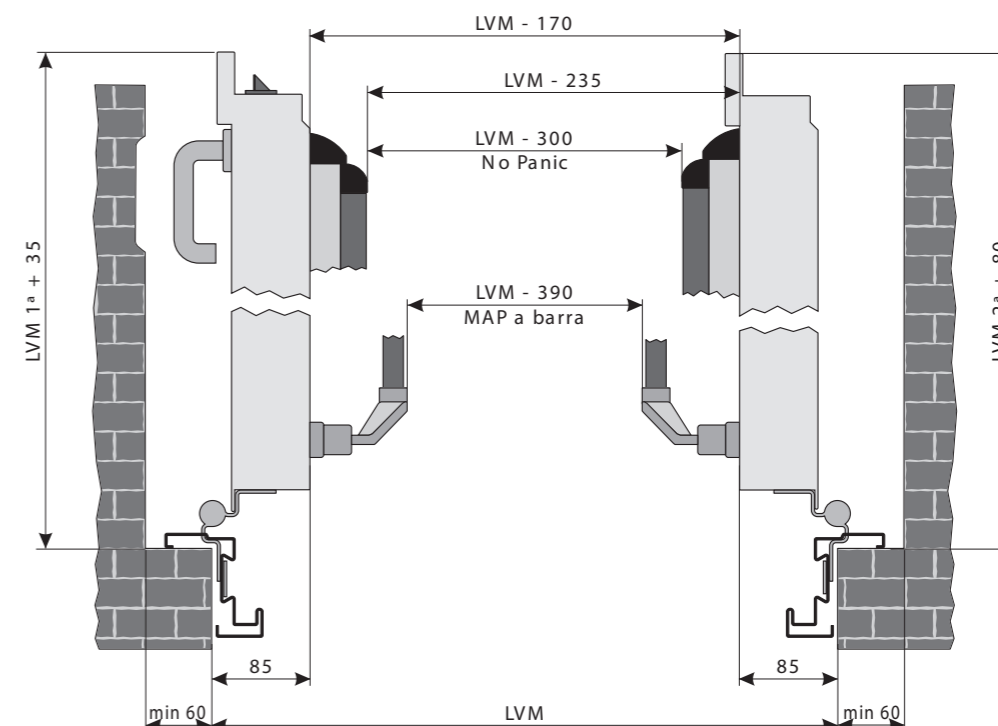

INGOMBRI PORTA CON APERTURA A 180°
 OPENING OVERALL DIMENSIONS WITH A 180° OPENING ANGLE

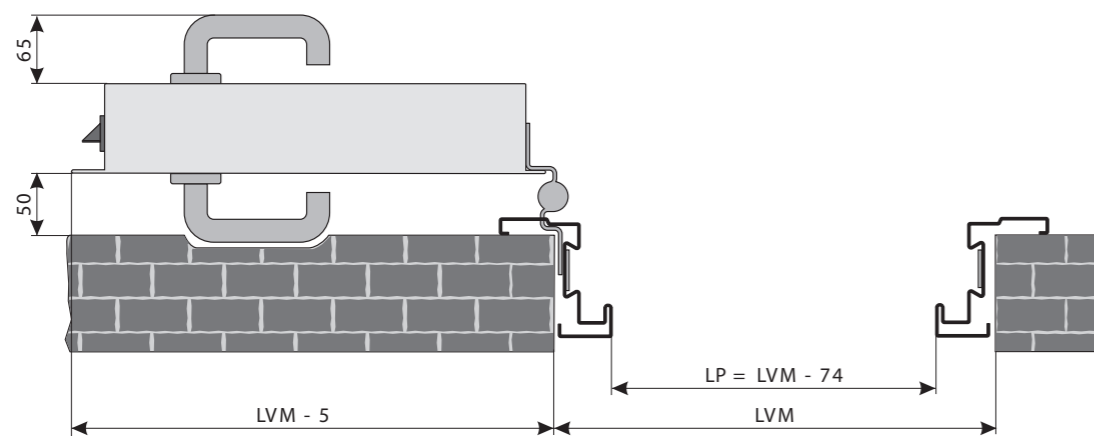

INGOMBRI PORTA CON APERTURA A 180°
 OPENING OVERALL DIMENSIONS WITH A 180° OPENING ANGLE

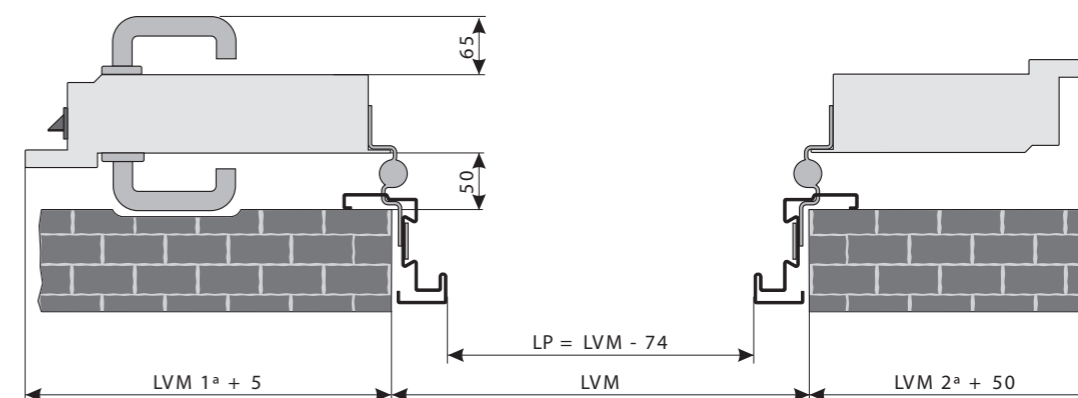

I disegni sono esemplificativi e fuori scala
 The drawings are an example and not in scale

Dierre si riserva il cambiamento della presente senza preavviso
 Dierrre holds the right to change this without notice

I disegni sono esemplificativi e fuori scala
 The drawings are an example and not in scale

Dierre si riserva il cambiamento della presente senza preavviso
 Dierrre holds the right to change this without notice

NEW IDRA FIREWALL DOOR 1 BATTENTE EI₂ 90
 NEW IDRA FIREWALL DOOR SINGLE LEAF EI₂ 90

INGOMBRI PORTA CON APERTURA A 90°
 OPENING OVERALL DIMENSIONS WITH A 90° OPENING ANGLE

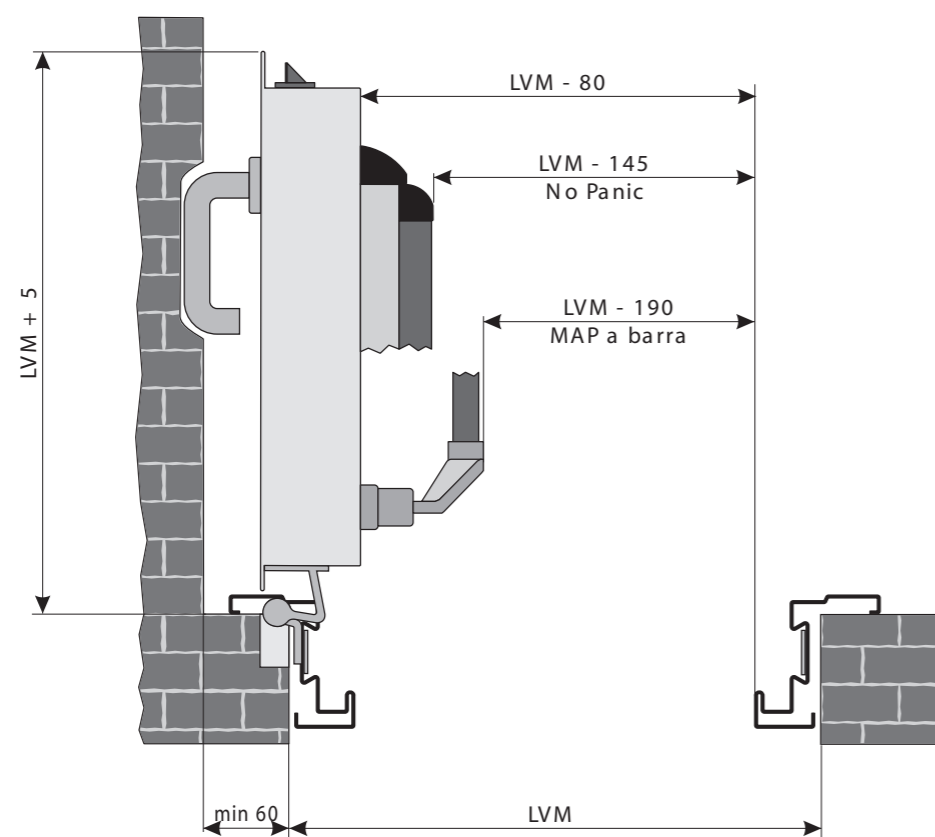

ATTENZIONE: MASSIMA APERTURA 100° CIRCA
 ATTENTION: MAXIMUM OPENING ANGLE APPROX. 100°

IDRA 1 BATTENTE EI₂ 30 CON TELAIO STANDARD
 IDRA SINGLE LEAF EI₂ 30 WITH STANDARD FRAME

INGOMBRI PORTA CON APERTURA A 90°
 OPENING OVERALL DIMENSIONS WITH A 90° OPENING ANGLE

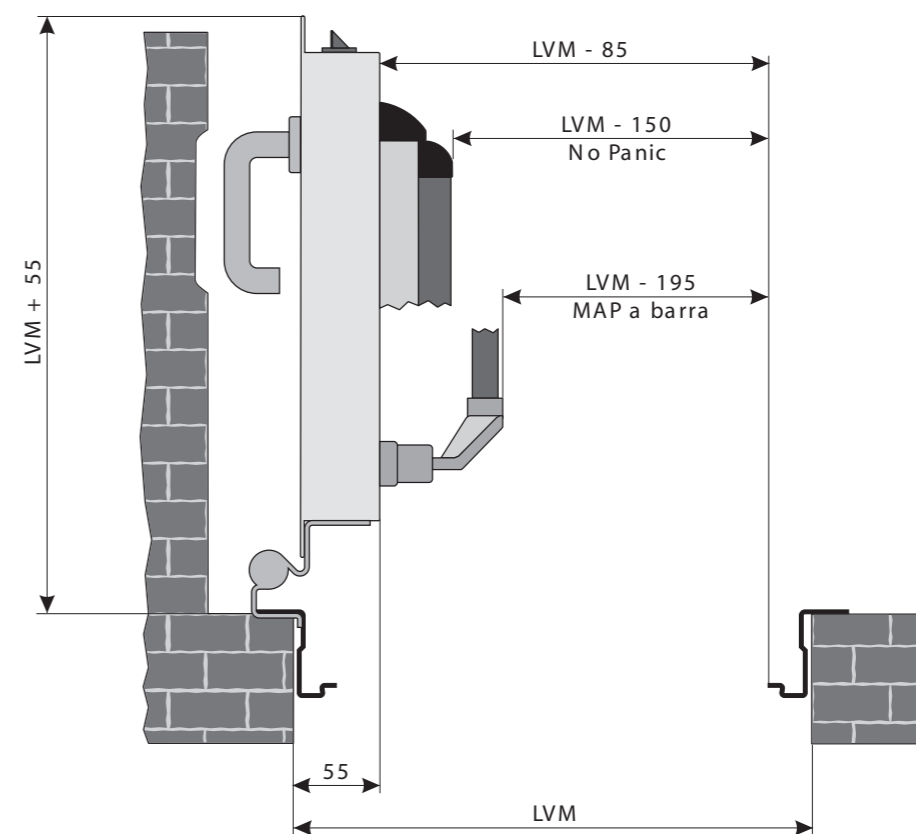

INGOMBRI PORTA CON APERTURA A 180°
 OPENING OVERALL DIMENSIONS WITH A 180° OPENING ANGLE

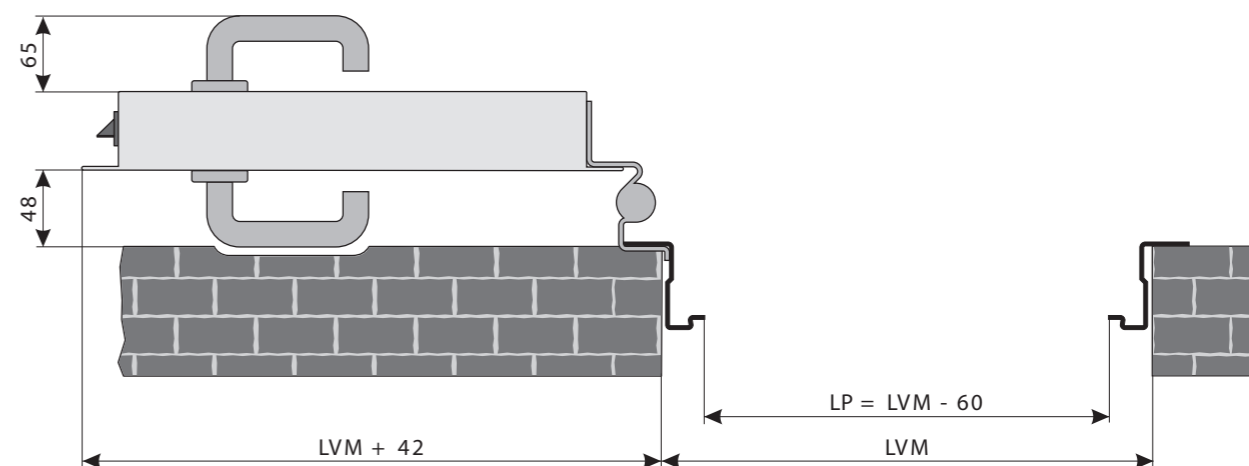

LE FINESTRATURE GLAZING

SOPRALUCE E FIANCHILUCE FANLIGHTS AND SIDELIGHTS

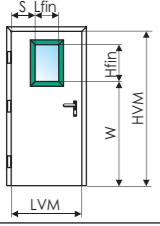
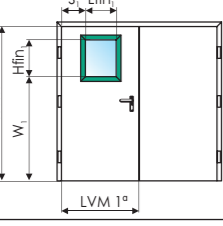
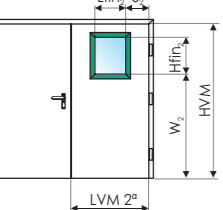
	FINESTRATURE CON MISURE STANDARD STANDARD SIZE GLAZING		FINESTRATURE CON MISURE A SCELTA GLAZIED AREA WITH SIZE UPON CLIENT'S CHOICE
	Lfin x Hfin	LARGHEZZA BATTENTE MIN. MINIMUM LEAF WIDTH	
	300 x 400	800	Lfin _{min} = 200 mm Hfin _{min} = 200 mm Lfin _{max} = 800 mm, Hfin _{max} = 600 mm S _{min} = 250 mm S _{max} = LVM - 250 - Lfin W _{min} = 250 mm W _{max} = HVM - 250 - Hfin
	400 x 600	900	
	200 x 600	700	
	300 x 600	800	
	400 x 600	900	
	300 x 400	800	Lfin _{1min} = 200 mm Hfin _{1min} = 200 mm Lfin _{1max} = 600 mm, Hfin _{1max} = 400 mm S _{1min} = 250 mm S _{1max} = LVM 1° - 250 - Lfin ₁ W _{1min} = 250 mm W _{1max} = HVM - 250 - Hfin ₁
	200 x 400	700	
	300 x 400	800	Lfin _{2min} = 200 mm Hfin _{2min} = 200 mm Se Lfin _{2max} = 600 mm, Hfin _{2max} = 400 mm S _{2min} = 250 mm S _{2max} = LVM 2° - 250 - Lfin ₂ W _{2min} = 250 mm W _{2max} = HVM - 250 - Hfin ₂
	200 x 400	700	

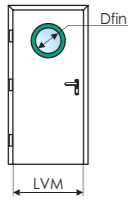
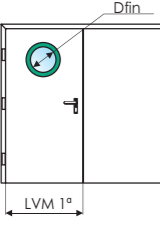
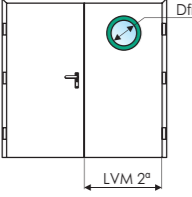
	FINESTRATURE CON MISURE STANDARD STANDARD SIZE GLAZING		FINESTRATURE CON MISURE A SCELTA GLAZIED AREA WITH SIZE UPON CLIENT'S CHOICE
	Dfin	LARGHEZZA BATTENTE MIN. MINIMUM LEAF WIDTH	
	Ø 300	800	NON DISPONIBILE NOT AVAILABLE
	Ø 400	900	
	Ø 300	800	
	Ø 400	900	
	Ø 300	800	
	Ø 400	900	

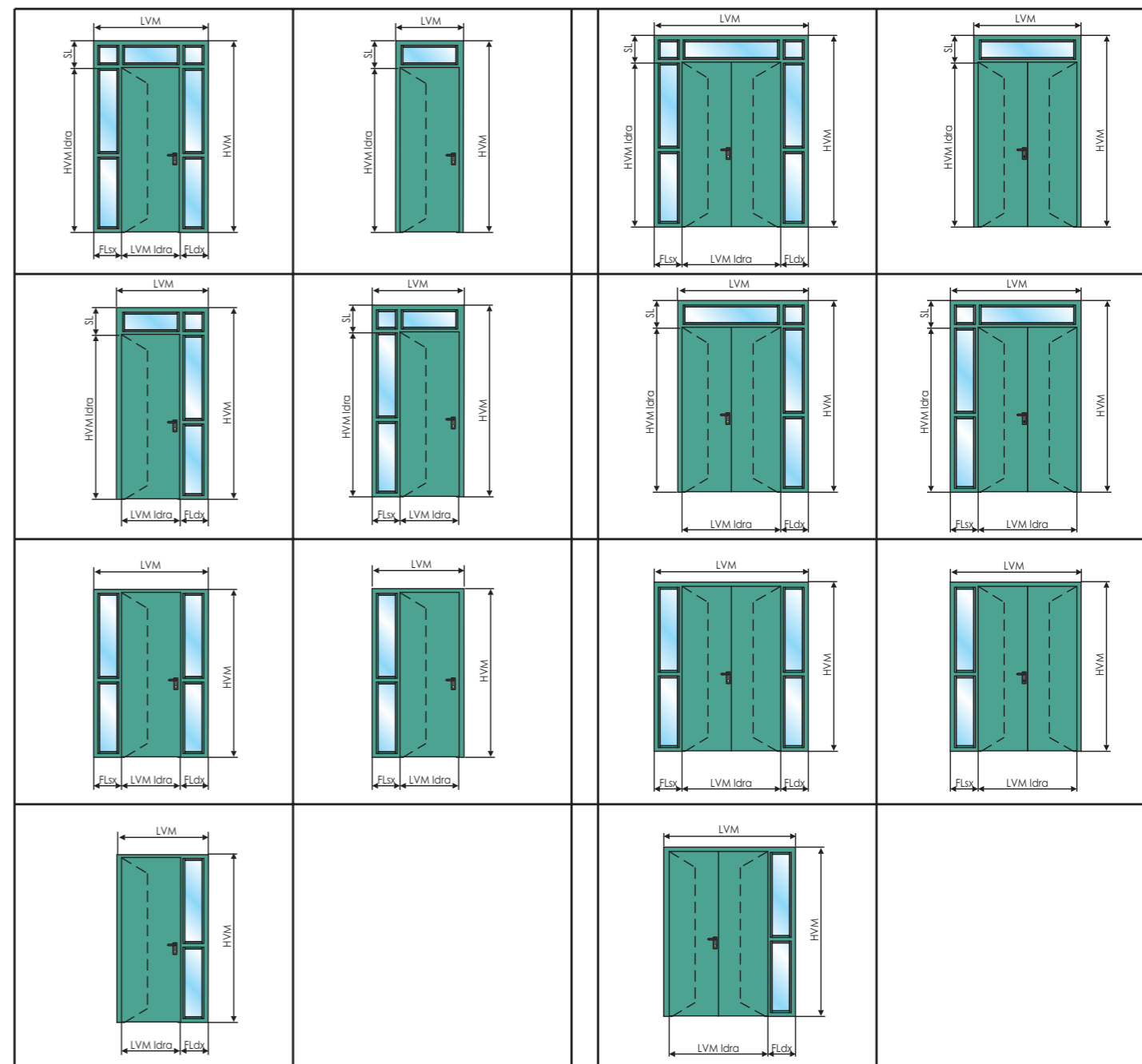

FINITURE MANIGLIONI NO PANIC

HANDLES NO PANIC FINISH



Nero/Rosso
Black/Red



Nero/Grigio
Black/Grey



Grigio
Grey

SCHEDE TECNICHE

TECHNICAL SHEETS



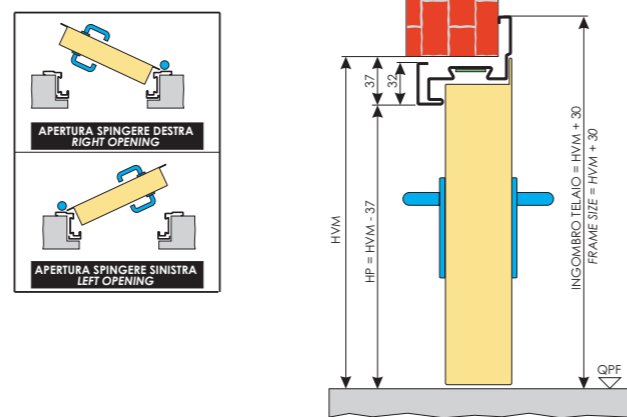
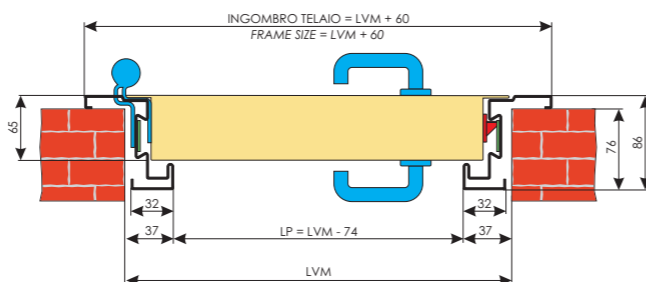
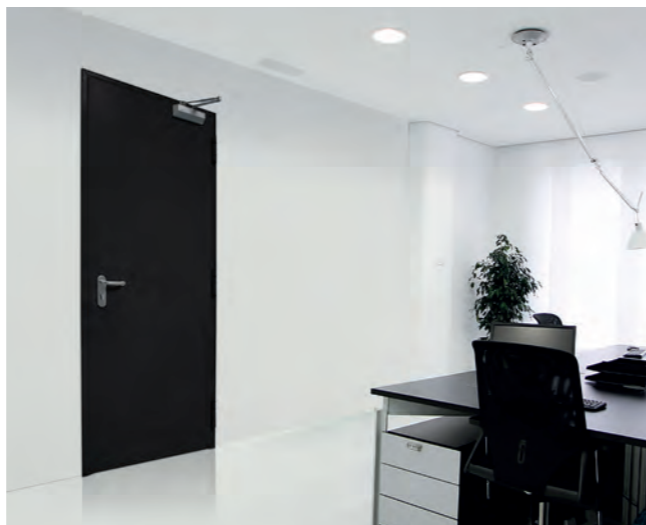

CARATTERISTICHE PRESTAZIONALI STANDARD STANDARD PERFORMANCE FEATURES	
TRASMITTANZA TERMICA THERMAL TRANSMITTANCE	1,4 W/m²K
ABBATTIMENTO ACUSTICO NOISE REDUCTION	19 dB
DI SERIE STANDARD	
MANIGLIA + MANIGLIA CON SERRATURA ANTINCENDIO HANDLE + HANDLE WITH FIRE RESISTANT LOCK	
CERNIERE A VISTA EXPOSED HINGES	
PESO WEIGHT	35 kg/m²
CARATTERISTICHE PRESTAZIONALI SUPPLEMENTARI OPTIONAL PERFORMANCE FEATURES	
KIT FUMI FREDDI (S _c) COLD FUMES KIT (S _c) KIT FUMI CALDI (S _m /S ₂₀₀) HOT FUMES KIT (S _m /S ₂₀₀)	SI / YES
ABBATTIMENTO ACUSTICO con soglia mobile NOISE REDUCTION with mobile threshold	27 dB
ABBATTIMENTO ACUSTICO con soglia fissa (uscita NON CONFORME alle uscite d'emergenza) NOISE REDUCTION with fixed threshold (this exit is NOT COMPLIANT with emergency exit requirements)	34 dB
PERMEABILITÀ ALL'ARIA E RESISTENZA AL CARICO DEL VENTO PERMEABILITY TO AIR AND RESISTANCE TO THE WIND LOAD	classe 4 C4
PORTA PER ESTERNI EN 14351-1 * Abbinare sempre almeno la guarnizione di battuta EXTERNAL DOOR EN 14351-1 * Always match at least the door stop seal	CE SI / YES
VARIANTI SUPPLEMENTARI ADDITIONAL VARIATIONS	
FINISTRATURA RETTANGOLARE/OBLÒ (vedi limiti a pagina 22) SQUARE WINDOW / ROUND WINDOW (see limits on page 22)	SI / YES
SOPRALUCE/FIANCOLUCE FANLIGHT/SIDELIGHT	SI / YES
ZOCOLO/FASCIA PARACOLPI BUMPER SKIRTING/BAND	SI / YES
CERNIERE A 3 ALI 3-FLAP HINGES	SI / YES
MANIGLIERIA ANTIPANICO PANIC EXIT BAR	SI / YES
SERRATURA A 3 PUNTI DI CHIUSURA 3 LOCK POINTS LOCK	SI / YES
MANIGLIERIA CONFORME ALLE NORME DIN DIN COMPLIANT HANDLES	SI / YES
CONTROLLO ACCESSI ACCESS MONITORING	
SBLOCCO ELETTRICO ELECTRIC UNLOCK	SI / YES
ELETTROMANIGLIA ELECTROHANDLE	SI / YES
SERRATURA ELETTRICA ELECTRIC LOCK	SI / YES
ELETTROMAGNETI ELECTROMAGNETS	SI / YES
ELETTROBLOCCHI MAGNETICI MAGNETIC ELECTRIC BLOCKS	SI / YES
DIMENSIONI CERTIFICATE CERTIFIED DIMENSIONS (Per la disponibilità nella propria nazione, chiedere al ns ufficio tecnico) (Ask our technical assistance office for availability in your country)	
LARGHEZZA (LVM) WIDTH (LVM)	675 ÷ 1350
ALTEZZA (HVM) HEIGHT (HVM)	1987 ÷ 2650



I disegni sono esemplificativi e fuori scala
Dierre si riserva il cambiamento della presente senza preavviso
Le quote sono espresse in millimetri

Drawing are examples and not in scale
Dierre holds the right to change this without notice
Dimensions are expressed in millimetres

* Per la compatibilità con i vari extra consultare il listino prezzi
For compatibility with the various extras refer to the price list



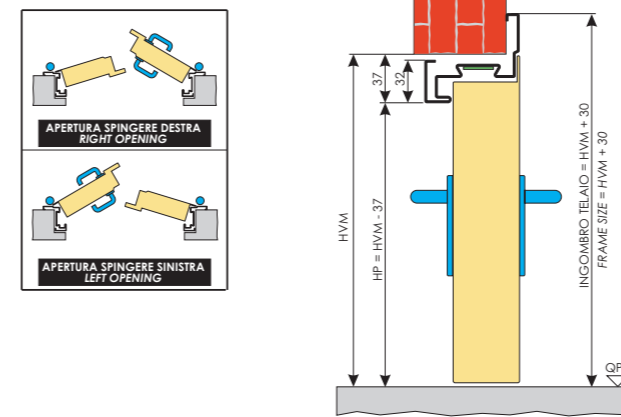
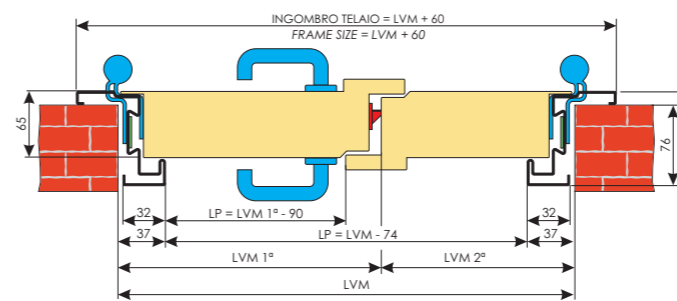
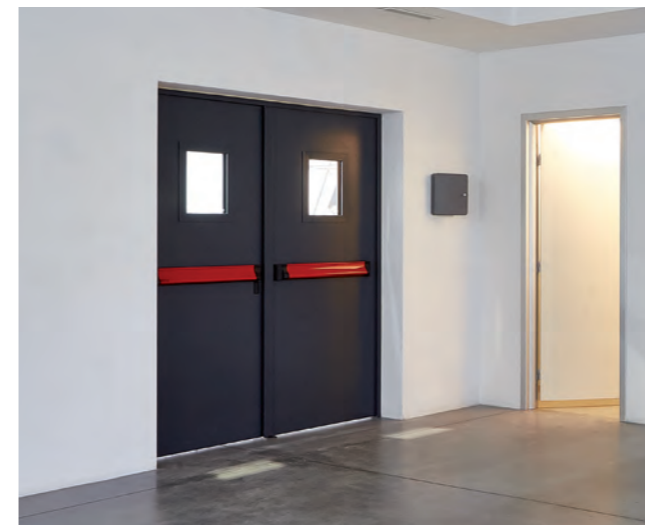

FINITURE FINISHINGS	
LACCATA RAL PER ESTERNI EXTERIOR RAL LACQUER	SI / YES
IN ACCIAIO INOX STAINLESS STEEL	SI / YES
IN ACCIAIO PRERIVESTITO PRE-COATED STEEL	SI / YES
TIPOLOGIE DI MONTAGGIO MOUNTING SOLUTIONS	
CON ZANCHE WITH TIES	
SU CONTROTELAIO ON SUB-FRAME	
CON TASSELLI WITH BOLTS	
SU MAZZETTA ON REVEAL	



I disegni sono esemplificativi e fuori scala
Dierre si riserva il cambiamento della presente senza preavviso
Le quote sono espresse in millimetri

Drawing are examples and not in scale
Dierre holds the right to change this without notice
Dimensions are expressed in millimetres

* Per la compatibilità con i vari extra consultare il listino prezzi
For compatibility with the various extras refer to the price list

FINITURE FINISHINGS	
LACCATA RAL PER ESTERNI EXTERIOR RAL LACQUER	SI / YES
IN ACCIAIO INOX STAINLESS STEEL	SI / YES
IN ACCIAIO PRERIVESTITO PRE-COATED STEEL	SI / YES
TIPOLOGIE DI MONTAGGIO MOUNTING SOLUTIONS	
CON ZANCHE WITH TIES	
SU CONTROTELAIO ON SUB-FRAME	
CON TASSELLI WITH BOLTS	
SU MAZZETTA ON REVEAL	

CARATTERISTICHE PRESTAZIONALI STANDARD STANDARD PERFORMANCE FEATURES	
TRASMITTANZA TERMICA THERMAL TRANSMITTANCE	1,7 W/m²K
ABBATTIMENTO ACUSTICO NOISE REDUCTION	19 dB
DI SERIE STANDARD	
MANIGLIA + MANIGLIA CON SERRATURA ANTINCENDIO HANDLE + HANDLE WITH FIRE RESISTANT LOCK	
CERNIERE A VISTA EXPOSED HINGES	
PESO WEIGHT	35 kg/m²
CARATTERISTICHE PRESTAZIONALI SUPPLEMENTARI OPTIONAL PERFORMANCE FEATURES	
KIT FUMI FREDDI (S _c) COLD FUMES KIT (S _c) KIT FUMI CALDI (S _m /S ₂₀₀) HOT FUMES KIT (S _m /S ₂₀₀)	SI / YES
ABBATTIMENTO ACUSTICO con soglia mobile NOISE REDUCTION with mobile threshold	25 dB
ABBATTIMENTO ACUSTICO con soglia fissa (uscita NON CONFORME alle uscite d'emergenza) NOISE REDUCTION with fixed threshold (this exit is NOT COMPLIANT with emergency exit requirements)	30 dB
PERMEABILITÀ ALL'ARIA E RESISTENZA AL CARICO DEL VENTO PERMEABILITY TO AIR AND RESISTANCE TO THE WIND LOAD	classe 4 C4
PORTA PER ESTERNI EN 14351-1 * Abbinare sempre almeno la guarnizione di battuta EXTERNAL DOOR EN 14351-1 * Always match at least the door stop seal	CE SI / YES
VARIANTI SUPPLEMENTARI ADDITIONAL VARIATIONS	
FINISTRATURA RETTANGOLARE/OBLÒ (vedi limiti a pagina 22) SQUARE WINDOW / ROUND WINDOW (see limits on page 22)	SI / YES
SOPRALUCE/FIANCOLUCE FANLIGHT/SIDELIGHT	SI / YES
ZOCOLO/FASCIA PARACOLPI BUMPER SKIRTING/BAND	SI / YES
CERNIERE A 3 ALI 3-FLAP HINGES	SI / YES
MANIGLIERIA ANTIPANICO PANIC EXIT BAR	SI / YES
SERRATURA A 3 PUNTI DI CHIUSURA 3 LOCK POINTS LOCK	SI / YES
MANIGLIERIA CONFORME ALLE NORME DIN DIN COMPLIANT HANDLES	SI / YES
CONTROLLO ACCESSI ACCESS MONITORING	
SBLOCCO ELETTRICO ELECTRIC UNLOCK	SI / YES
ELETTROMANIGLIA ELECTROHANDLE	SI / YES
SERRATURA ELETTRICA ELECTRIC LOCK	SI / YES
ELETTROMAGNETI ELECTROMAGNETS	SI / YES
ELETTROBLOCCHI MAGNETICI MAGNETIC ELECTRIC BLOCKS	SI / YES
DIMENSIONI CERTIFICATE CERTIFIED DIMENSIONS (Per la disponibilità nella propria nazione, chiedere al ns ufficio tecnico) (Ask our technical assistance office for availability in your country)	
LARGHEZZA (LVM) WIDTH (LVM)	950 ÷ 2600 (600 + 350) ÷ (1300 + 1300)
ALTEZZA (HVM) HEIGHT (HVM)	1987 ÷ 2650

CARATTERISTICHE PRESTAZIONALI STANDARD
STANDARD PERFORMANCE FEATURES

TRASMITTANZA TERMICA THERMAL TRANSMITTANCE		1,4 W/m²K
ABBATTIMENTO ACUSTICO NOISE REDUCTION		19 dB
DI SERIE STANDARD		
MANIGLIA + MANIGLIA CON SERRATURA ANTINCENDIO HANDLE + HANDLE WITH FIRE RESISTANT LOCK		
CERNIERE A VISTA EXPOSED HINGES		
PESO WEIGHT		35 kg/m²

CARATTERISTICHE PRESTAZIONALI SUPPLEMENTARI
OPTIONAL PERFORMANCE FEATURES

KIT FUMI FREDDI (S _c) COLD FUMES KIT (S _c) KIT FUMI CALDI (S _m /S ₂₀₀) HOT FUMES KIT (S _m /S ₂₀₀)		SI / YES
ABBATTIMENTO ACUSTICO con soglia mobile NOISE REDUCTION with mobile threshold		27 dB
ABBATTIMENTO ACUSTICO con soglia fissa (uscita NON CONFORME alle uscite d'emergenza) NOISE REDUCTION with fixed threshold (this exit is NOT COMPLIANT with emergency exit requirements)		34 dB
PERMEABILITÀ ALL'ARIA E RESISTENZA AL CARICO DEL VENTO PERMEABILITY TO AIR AND RESISTANCE TO THE WIND LOAD		classe 4 C4
PORTA PER ESTERNI EN 14351-1 * Abbinare sempre almeno la guarnizione di battuta EXTERNAL DOOR EN 14351-1 * Always match at least the door stop seal		SI / YES

VARIANTI SUPPLEMENTARI
ADDITIONAL VARIATIONS

FINISTRATURA RETTANGOLARE/OBLÒ (vedi limiti a pagina 22) SQUARE WINDOW / ROUND WINDOW (see limits on page 22)		SI / YES
SOPRALUCE/FIANCOLUCE FANLIGHT/SIDELIGHT		NO
ZOCCOLO/FASCIA PARACOLPI BUMPER SKIRTING/BAND		SI / YES
CERNIERE A 3 ALI 3-FLAP HINGES		SI / YES
MANIGLIERIA ANTIPANICO PANIC EXIT BAR		SI / YES
SERRATURA A 3 PUNTI DI CHIUSURA 3 LOCK POINTS LOCK		SI / YES
MANIGLIERIA CONFORME ALLE NORME DIN DIN COMPLIANT HANDLES		SI / YES

CONTROLLO ACCESSI
ACCESS MONITORING

SBLOCCO ELETTRICO ELECTRIC UNLOCK	SI / YES
ELETTROMANIGLIA ELECTROHANDLE	SI / YES
SERRATURA ELETTRICA ELECTRIC LOCK	SI / YES
ELETTROMAGNETI ELECTROMAGNETS	SI / YES
ELETTROBLOCCHI MAGNETICI MAGNETIC ELECTRIC BLOCKS	SI / YES

DIMENSIONI CERTIFICATE
CERTIFIED DIMENSIONS (Per la disponibilità nella propria nazione, chiedere al ns ufficio tecnico)
(Ask our technical assistance office for availability in your country)

LARGHEZZA (LVM) WIDTH (LVM)	675 ÷ 1350
ALTEZZA (HVM) HEIGHT (HVM)	1987 ÷ 2650

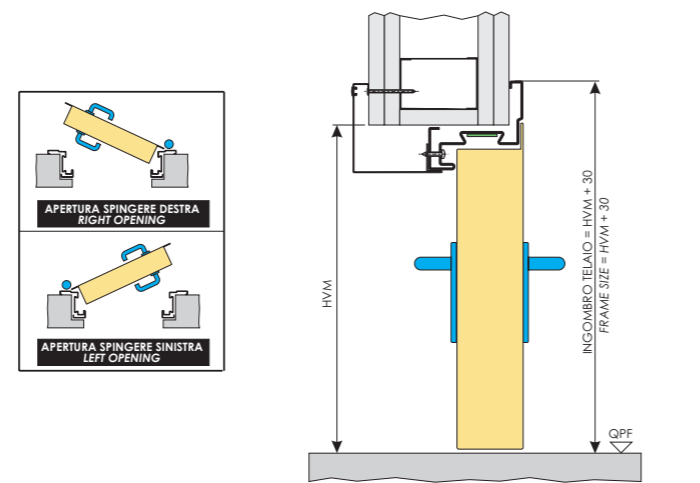
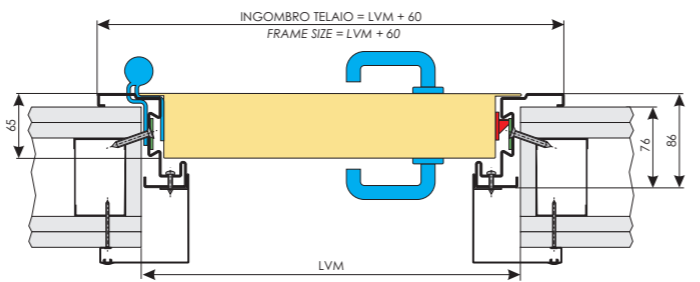

I disegni sono esemplificativi e fuori scala
Dierre si riserva il cambiamento della presente senza preavviso
Le quote sono espresse in millimetri

Drawing are examples and not in scale
Dierre holds the right to change this without notice
Dimensions are expressed in millimetres

L'imbotte non è necessario con la marcatura CE
The padding is not necessary with the CE marking

* Per la compatibilità con i vari extra consultare il listino prezzi
For compatibility with the various extras refer to the price list

FINITURE
FINISHINGS

LACCATA RAL PER ESTERNI EXTERIOR RAL LACQUER	SI / YES
IN ACCIAIO INOX STAINLESS STEEL	SI / YES
IN ACCIAIO PRERIVESTITO PRE-COATED STEEL	SI / YES

TIPOLOGIE DI MONTAGGIO
MOUNTING SOLUTIONS

SU PARETI IN CARTONGESSO ON PLASTERBOARD WALLS	
---	---

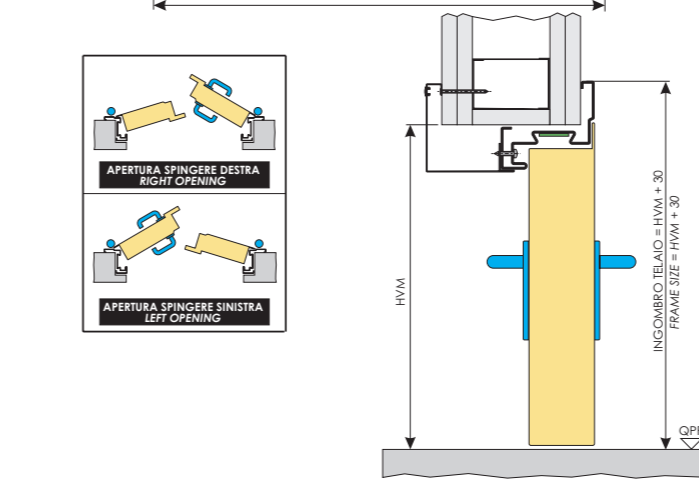
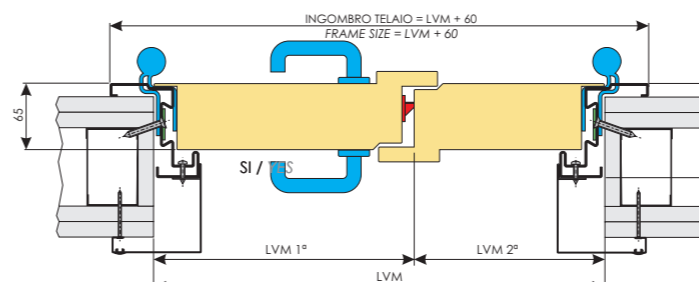

I disegni sono esemplificativi e fuori scala
Dierre si riserva il cambiamento della presente senza preavviso
Le quote sono espresse in millimetri

Drawing are examples and not in scale
Dierre holds the right to change this without notice
Dimensions are expressed in millimetres

L'imbotte non è necessario con la marcatura CE
The padding is not necessary with the CE marking

* Per la compatibilità con i vari extra consultare il listino prezzi
For compatibility with the various extras refer to the price list

FINITURE
FINISHINGS

LACCATA RAL PER ESTERNI EXTERIOR RAL LACQUER	SI / YES
IN ACCIAIO INOX STAINLESS STEEL	SI / YES
IN ACCIAIO PRERIVESTITO PRE-COATED STEEL	SI / YES

TIPOLOGIE DI MONTAGGIO
MOUNTING SOLUTIONS

SU PARETI IN CARTONGESSO ON PLASTERBOARD WALLS	
---	---

CARATTERISTICHE PRESTAZIONALI STANDARD
STANDARD PERFORMANCE FEATURES

TRASMITTANZA TERMICA THERMAL TRANSMITTANCE		1,7 W/m²K
ABBATTIMENTO ACUSTICO NOISE REDUCTION		19 dB
DI SERIE STANDARD		
MANIGLIA + MANIGLIA CON SERRATURA ANTINCENDIO HANDLE + HANDLE WITH FIRE RESISTANT LOCK		
CERNIERE A VISTA EXPOSED HINGES		
PESO WEIGHT		35 kg/m²

CARATTERISTICHE PRESTAZIONALI SUPPLEMENTARI
OPTIONAL PERFORMANCE FEATURES

KIT FUMI FREDDI (S _c) COLD FUMES KIT (S _c) KIT FUMI CALDI (S _m /S ₂₀₀) HOT FUMES KIT (S _m /S ₂₀₀)		SI / YES
ABBATTIMENTO ACUSTICO con soglia mobile NOISE REDUCTION with mobile threshold		25 dB
ABBATTIMENTO ACUSTICO con soglia fissa (uscita NON CONFORME alle uscite d'emergenza) NOISE REDUCTION with fixed threshold (this exit is NOT COMPLIANT with emergency exit requirements)		30 dB
PERMEABILITÀ ALL'ARIA E RESISTENZA AL CARICO DEL VENTO PERMEABILITY TO AIR AND RESISTANCE TO THE WIND LOAD		classe 4 C4
PORTA PER ESTERNI EN 14351-1 * Abbinare sempre almeno la guarnizione di battuta EXTERNAL DOOR EN 14351-1 * Always match at least the door stop seal		SI / YES

VARIANTI SUPPLEMENTARI
ADDITIONAL VARIATIONS

FINISTRATURA RETTANGOLARE/OBLÒ (vedi limiti a pagina 22) SQUARE WINDOW / ROUND WINDOW (see limits on page 22)		SI / YES
SOPRALUCE/FIANCOLUCE FANLIGHT/SIDELIGHT		NO
ZOCCOLO/FASCIA PARACOLPI BUMPER SKIRTING/BAND		SI / YES
CERNIERE A 3 ALI 3-FLAP HINGES		SI / YES
MANIGLIERIA ANTIPANICO PANIC EXIT BAR		SI / YES
SERRATURA A 3 PUNTI DI CHIUSURA 3 LOCK POINTS LOCK		SI / YES
MANIGLIERIA CONFORME ALLE NORME DIN DIN COMPLIANT HANDLES		SI / YES

CONTROLLO ACCESSI
ACCESS MONITORING

SBLOCCO ELETTRICO ELECTRIC UNLOCK	SI / YES
ELETTROMANIGLIA ELECTROHANDLE	SI / YES
SERRATURA ELETTRICA ELECTRIC LOCK	SI / YES
ELETTROMAGNETI ELECTROMAGNETS	SI / YES
ELETTROBLOCCHI MAGNETICI MAGNETIC ELECTRIC BLOCKS	SI / YES

DIMENSIONI CERTIFICATE
CERTIFIED DIMENSIONS (Per la disponibilità nella propria nazione, chiedere al ns ufficio tecnico)
(Ask our technical assistance office for availability in your country)

LARGHEZZA (LVM) WIDTH (LVM)	1150 ÷ 2300 (575 + 575) ÷ (1150 + 1150)
ALTEZZA (HVM) HEIGHT (HVM)	1987 ÷ 2650



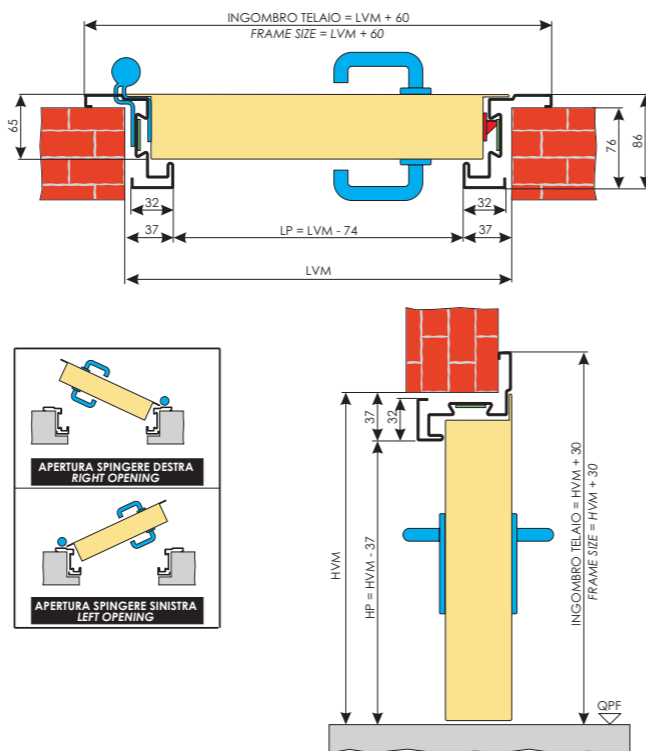

CARATTERISTICHE PRESTAZIONALI STANDARD STANDARD PERFORMANCE FEATURES	
TRASMITTANZA TERMICA THERMAL TRANSMITTANCE	1,4 W/m²K
ABBATTIMENTO ACUSTICO NOISE REDUCTION	20 dB
DI SERIE STANDARD	
MANIGLIA + MANIGLIA CON SERRATURA ANTINCENDIO HANDLE + HANDLE WITH FIRE RESISTANT LOCK	
CERNIERE A VISTA EXPOSED HINGES	
PESO WEIGHT	40 kg/m²
CARATTERISTICHE PRESTAZIONALI SUPPLEMENTARI OPTIONAL PERFORMANCE FEATURES	
KIT FUMI FREDDI (S ₀) COLD FUMES KIT (S ₀)	SI / YES
KIT FUMI CALDI (S _m /S ₂₀₀) HOT FUMES KIT (S _m /S ₂₀₀)	SI / YES
ABBATTIMENTO ACUSTICO con soglia mobile NOISE REDUCTION with mobile threshold	29 dB
ABBATTIMENTO ACUSTICO con soglia fissa (uscita NON CONFORME alle uscite d'emergenza) NOISE REDUCTION with fixed threshold (this exit is NOT COMPLIANT with emergency exit requirements)	35 dB
PERMEABILITÀ ALL'ARIA E RESISTENZA AL CARICO DEL VENTO PERMEABILITY TO AIR AND RESISTANCE TO THE WIND LOAD	classe 4 C4
PORTA PER ESTERNI EN 14351-1 * Abbinare sempre almeno la guarnizione di battuta EXTERNAL DOOR EN 14351-1 * Always match at least the door stop seal	CE SI / YES
VARIANTI SUPPLEMENTARI ADDITIONAL VARIATIONS	
FINISTRATURA RETTANGOLARE/OBLÒ (vedi limiti a pagina 22) SQUARE WINDOW / ROUND WINDOW (see limits on page 22)	SI / YES
SOPRALUCE/FIANCOLUCE FANLIGHT/SIDELIGHT	SI / YES
ZOCCOLO/FASCIA PARACOLPI BUMPER SKIRTING/BAND	SI / YES
CERNIERE A 3 ALI 3-FLAP HINGES	SI / YES
MANIGLIERIA ANTIPANICO PANIC EXIT BAR	SI / YES
SERRATURA A 3 PUNTI DI CHIUSURA 3 LOCK POINTS LOCK	SI / YES
MANIGLIERIA CONFORME ALLE NORME DIN DIN COMPLIANT HANDLES	SI / YES
CONTROLLO ACCESSI ACCESS MONITORING	
SBLOCCO ELETTRICO ELECTRIC UNLOCK	SI / YES
ELETTROMANIGLIA ELECTROHANDLE	SI / YES
SERRATURA ELETTRICA ELECTRIC LOCK	SI / YES
ELETTROMAGNETI ELECTROMAGNETS	SI / YES
ELETTROBLOCCHI MAGNETICI MAGNETIC ELECTRIC BLOCKS	SI / YES
DIMENSIONI CERTIFICATE CERTIFIED DIMENSIONS (Per la disponibilità nella propria nazione, chiedere al ns ufficio tecnico) (Ask our technical assistance office for availability in your country)	
LARGHEZZA (LVM) WIDTH (LVM)	675 ÷ 1350
ALTEZZA (HVM) HEIGHT (HVM)	1987 ÷ 2650



I disegni sono esemplificativi e fuori scala
Dierre si riserva il cambiamento della presente senza preavviso
Le quote sono espresse in millimetri

Drawing are examples and not in scale.
Dierre holds the right to change this without notice.
Dimensions are expressed in millimetres

* Per la compatibilità con i vari extra consultare il listino prezzi
For compatibility with the various extras refer to the price list

FINITURE FINISHINGS	
LACCATA RAL PER ESTERNI EXTERIOR RAL LACQUER	SI / YES
IN ACCIAIO INOX STAINLESS STEEL	SI / YES
IN ACCIAIO PRERIVESTITO PRE-COATED STEEL	SI / YES
TIPOLOGIE DI MONTAGGIO MOUNTING SOLUTIONS	
CON ZANCHE WITH TIES	
SU CONTROTELAIO ON SUB-FRAME	
CON TASSELLI WITH BOLTS	
SU MAZZETTA ON REVEAL	

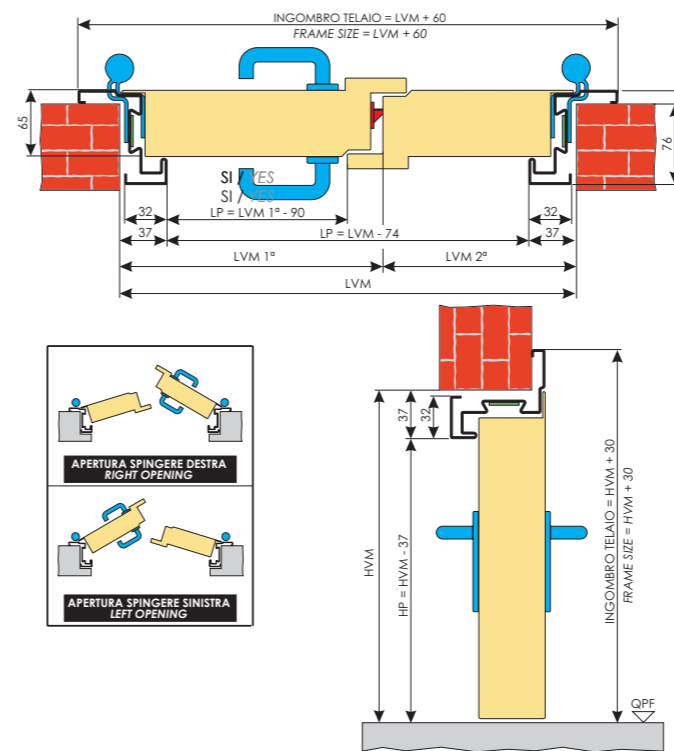





I disegni sono esemplificativi e fuori scala. Dierre si riserva il cambiamento della presente senza preavviso. Le quote sono espresse in millimetri

Drawing are examples and not in scale. Dierre holds the right to change this without notice. Dimensions are expressed in millimetres

* Per la compatibilità con i vari extra consultare il listino prezzi
For compatibility with the various extras refer to the price list

▫ Solo per porte certificate per esterni EN 14351-1
Only for EN 14351-1 certified exterior doors

FINITURE FINISHINGS	
LACCATA RAL PER ESTERNI EXTERIOR RAL LACQUER	SI / YES
IN ACCIAIO INOX STAINLESS STEEL	SI / YES ▫
IN ACCIAIO PRERIVESTITO PRE-COATED STEEL	SI / YES
TIPOLOGIE DI MONTAGGIO MOUNTING SOLUTIONS	
CON ZANCHE WITH TIES	
SU CONTROTELAIO ON SUB-FRAME	
CON TASSELLI WITH BOLTS	
SU MAZZETTA ON REVEAL	

CARATTERISTICHE PRESTAZIONALI STANDARD STANDARD PERFORMANCE FEATURES	
TRASMITTANZA TERMICA THERMAL TRANSMITTANCE	1,7 W/m²K
ABBATTIMENTO ACUSTICO NOISE REDUCTION	N.D.
DI SERIE STANDARD	
MANIGLIA + MANIGLIA CON SERRATURA ANTINCENDIO HANDLE + HANDLE WITH FIRE RESISTANT LOCK	
CERNIERE A VISTA EXPOSED HINGES	
PESO WEIGHT	40 kg/m²
CARATTERISTICHE PRESTAZIONALI SUPPLEMENTARI OPTIONAL PERFORMANCE FEATURES	
KIT FUMI FREDDI (S ₀) COLD FUMES KIT (S ₀)	SI / YES
KIT FUMI CALDI (S _m /S ₂₀₀) HOT FUMES KIT (S _m /S ₂₀₀)	SI / YES
ABBATTIMENTO ACUSTICO con soglia mobile NOISE REDUCTION with mobile threshold	32 dB
ABBATTIMENTO ACUSTICO con soglia fissa (uscita NON CONFORME alle uscite d'emergenza) NOISE REDUCTION with fixed threshold (this exit is NOT COMPLIANT with emergency exit requirements)	36 dB
PERMEABILITÀ ALL'ARIA E RESISTENZA AL CARICO DEL VENTO PERMEABILITY TO AIR AND RESISTANCE TO THE WIND LOAD	classe 4 C4
PORTA PER ESTERNI EN 14351-1 * Abbinare sempre almeno la guarnizione di battuta EXTERNAL DOOR EN 14351-1 * Always match at least the door stop seal	CE SI / YES
VARIANTI SUPPLEMENTARI ADDITIONAL VARIATIONS	
FINISTRATURA RETTANGOLARE/OBLÒ (vedi limiti a pagina 22) SQUARE WINDOW / ROUND WINDOW (see limits on page 22)	SI / YES
SOPRALUCE/FIANCOLUCE FANLIGHT/SIDELIGHT	SI / YES
ZOCCOLO/FASCIA PARACOLPI BUMPER SKIRTING/BAND	SI / YES
CERNIERE A 3 ALI 3-FLAP HINGES	SI / YES ▫
MANIGLIERIA ANTIPANICO PANIC EXIT BAR	SI / YES
SERRATURA A 3 PUNTI DI CHIUSURA 3 LOCK POINTS LOCK	SI / YES
MANIGLIERIA CONFORME ALLE NORME DIN DIN COMPLIANT HANDLES	SI / YES
CONTROLLO ACCESSI ACCESS MONITORING	
SBLOCCO ELETTRICO ELECTRIC UNLOCK	SI / YES
ELETTROMANIGLIA ELECTROHANDLE	SI / YES
SERRATURA ELETTRICA ELECTRIC LOCK	SI / YES
ELETTROMAGNETI ELECTROMAGNETS	SI / YES
ELETTROBLOCCHI MAGNETICI MAGNETIC ELECTRIC BLOCKS	SI / YES
DIMENSIONI CERTIFICATE CERTIFIED DIMENSIONS (Per la disponibilità nella propria nazione, chiedere al ns ufficio tecnico) (Ask our technical assistance office for availability in your country)	
LARGHEZZA (LVM) WIDTH (LVM)	950 ÷ 2600 (600 + 350) ÷ (1300 + 1300)
ALTEZZA (HVM) HEIGHT (HVM)	1987 ÷ 2650

CARATTERISTICHE PRESTAZIONALI STANDARD STANDARD PERFORMANCE FEATURES	
TRASMITTANZA TERMICA THERMAL TRANSMITTANCE	1,4 W/m²K
ABBATTIMENTO ACUSTICO NOISE REDUCTION	20 dB
DI SERIE STANDARD	
MANIGLIA + MANIGLIA CON SERRATURA ANTINCENDIO HANDLE + HANDLE WITH FIRE RESISTANT LOCK	
CERNIERE A VISTA EXPOSED HINGES	
PESO WEIGHT	40 kg/m²
CARATTERISTICHE PRESTAZIONALI SUPPLEMENTARI OPTIONAL PERFORMANCE FEATURES	
KIT FUMI FREDDI (S _c) COLD FUMES KIT (S _c) KIT FUMI CALDI (S _m /S ₂₀₀) HOT FUMES KIT (S _m /S ₂₀₀)	SI / YES
ABBATTIMENTO ACUSTICO con soglia mobile NOISE REDUCTION with mobile threshold	29 dB
ABBATTIMENTO ACUSTICO con soglia fissa (uscita NON CONFORME alle uscite d'emergenza) NOISE REDUCTION with fixed threshold (this exit is NOT COMPLIANT with emergency exit requirements)	35 dB
PERMEABILITÀ ALL'ARIA E RESISTENZA AL CARICO DEL VENTO PERMEABILITY TO AIR AND RESISTANCE TO THE WIND LOAD	classe 4 C4
PORTA PER ESTERNI EN 14351-1 * Abbinare sempre almeno la guarnizione di battuta EXTERNAL DOOR EN 14351-1 * Always match at least the door stop seal	CE SI / YES
VARIANTI SUPPLEMENTARI ADDITIONAL VARIATIONS	
FINISTRATURA RETTANGOLARE/OBLÒ (vedi limiti a pagina 22) SQUARE WINDOW / ROUND WINDOW (see limits on page 22)	SI / YES
SOPRALUCE/FIANCOLUCE FANLIGHT/SIDELIGHT	NO
ZOCOLO/FASCIA PARACOLPI BUMPER SKIRTING/BAND	SI / YES
CERNIERE A 3 ALI 3-FLAP HINGES	SI / YES
MANIGLIERIA ANTIPANICO PANIC EXIT BAR	SI / YES
SERRATURA A 3 PUNTI DI CHIUSURA 3 LOCK POINTS LOCK	SI / YES
MANIGLIERIA CONFORME ALLE NORME DIN DIN COMPLIANT HANDLES	SI / YES
CONTROLLO ACCESSI ACCESS MONITORING	
SBLOCCO ELETTRICO ELECTRIC UNLOCK	SI / YES
ELETTROMANIGLIA ELECTROHANDLE	SI / YES
SERRATURA ELETTRICA ELECTRIC LOCK	SI / YES
ELETTROMAGNETI ELECTROMAGNETS	SI / YES
ELETTROBLOCCHI MAGNETICI MAGNETIC ELECTRIC BLOCKS	SI / YES
DIMENSIONI CERTIFICATE CERTIFIED DIMENSIONS (Per la disponibilità nella propria nazione, chiedere al ns ufficio tecnico) (Ask our technical assistance office for availability in your country)	
LARGHEZZA (LVM) WIDTH (LVM)	675 ÷ 1350
ALTEZZA (HVM) HEIGHT (HVM)	1987 ÷ 2650

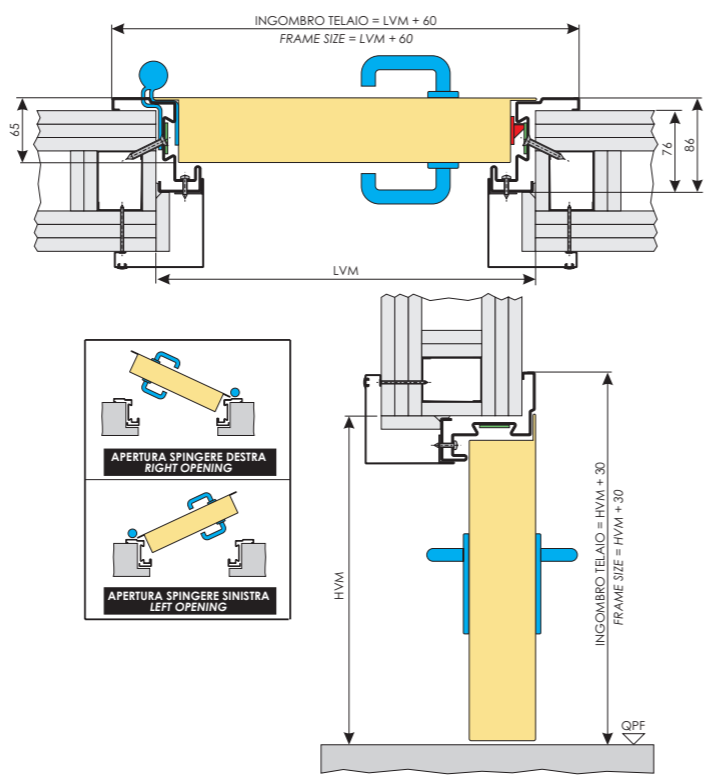

I disegni sono esemplificativi e fuori scala. Dierre si riserva il cambiamento della presente senza preavviso. Le quote sono espresse in millimetri.
Drawing are examples and not in scale. Dierre holds the right to change this without notice. Dimensions are expressed in millimetres.

L'imbotte non è necessario con la marcatura CE.
The padding is not necessary with the CE marking.

* Per la compatibilità con i vari extra consultare il listino prezzi.
For compatibility with the various extras refer to the price list.

FINITURE FINISHINGS	
LACCATA RAL PER ESTERNI EXTERIOR RAL LACQUER	SI / YES
IN ACCIAIO INOX STAINLESS STEEL	SI / YES
IN ACCIAIO PRERIVESTITO PRE-COATED STEEL	SI / YES
TIPOLOGIE DI MONTAGGIO MOUNTING SOLUTIONS	
SU PARETI IN CARTONGESSO ON PLASTERBOARD WALLS	

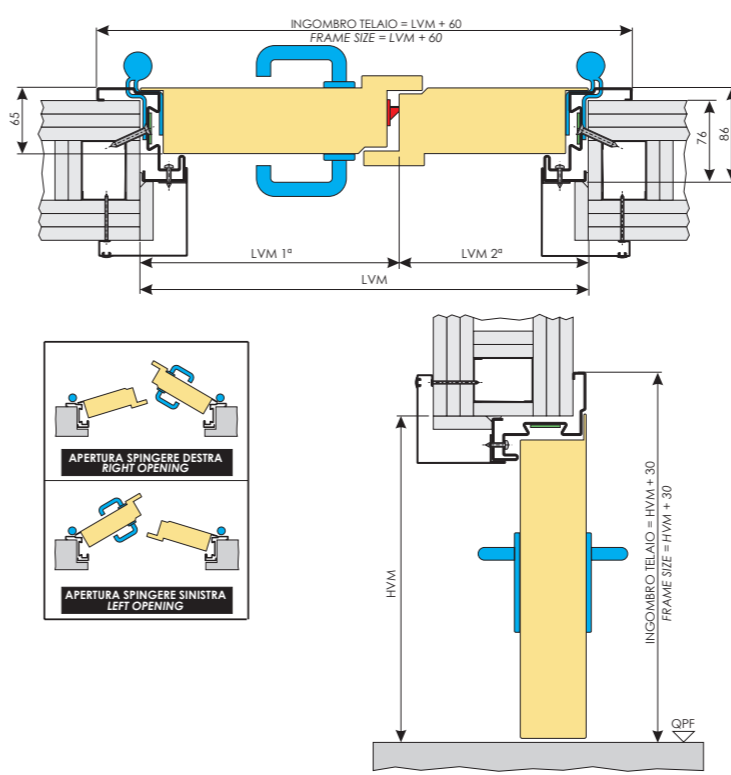

I disegni sono esemplificativi e fuori scala. Dierre si riserva il cambiamento della presente senza preavviso. Le quote sono espresse in millimetri.
Drawing are examples and not in scale. Dierre holds the right to change this without notice. Dimensions are expressed in millimetres.

L'imbotte non è necessario con la marcatura CE.
The padding is not necessary with the CE marking.

* Per la compatibilità con i vari extra consultare il listino prezzi.
For compatibility with the various extras refer to the price list.

▫ Solo per porte certificate per esterni EN 14351-1.
Only for EN 14351-1 certified exterior doors.

FINITURE FINISHINGS	
LACCATA RAL PER ESTERNI EXTERIOR RAL LACQUER	SI / YES
IN ACCIAIO INOX STAINLESS STEEL	SI / YES ▫
IN ACCIAIO PRERIVESTITO PRE-COATED STEEL	SI / YES
TIPOLOGIE DI MONTAGGIO MOUNTING SOLUTIONS	
SU PARETI IN CARTONGESSO ON PLASTERBOARD WALLS	

CARATTERISTICHE PRESTAZIONALI STANDARD STANDARD PERFORMANCE FEATURES	
TRASMITTANZA TERMICA THERMAL TRANSMITTANCE	1,7 W/m²K
ABBATTIMENTO ACUSTICO NOISE REDUCTION	N.D.
DI SERIE STANDARD	
MANIGLIA + MANIGLIA CON SERRATURA ANTINCENDIO HANDLE + HANDLE WITH FIRE RESISTANT LOCK	
CERNIERE A VISTA EXPOSED HINGES	
PESO WEIGHT	40 kg/m²
CARATTERISTICHE PRESTAZIONALI SUPPLEMENTARI OPTIONAL PERFORMANCE FEATURES	
KIT FUMI FREDDI (S _c) COLD FUMES KIT (S _c) KIT FUMI CALDI (S _m /S ₂₀₀) HOT FUMES KIT (S _m /S ₂₀₀)	SI / YES
ABBATTIMENTO ACUSTICO con soglia mobile NOISE REDUCTION with mobile threshold	29 dB
ABBATTIMENTO ACUSTICO con soglia fissa (uscita NON CONFORME alle uscite d'emergenza) NOISE REDUCTION with fixed threshold (this exit is NOT COMPLIANT with emergency exit requirements)	35 dB
PERMEABILITÀ ALL'ARIA E RESISTENZA AL CARICO DEL VENTO PERMEABILITY TO AIR AND RESISTANCE TO THE WIND LOAD	classe 4 C4
PORTA PER ESTERNI EN 14351-1 * Abbinare sempre almeno la guarnizione di battuta EXTERNAL DOOR EN 14351-1 * Always match at least the door stop seal	CE SI / YES
VARIANTI SUPPLEMENTARI ADDITIONAL VARIATIONS	
FINISTRATURA RETTANGOLARE/OBLÒ (vedi limiti a pagina 22) SQUARE WINDOW / ROUND WINDOW (see limits on page 22)	SI / YES
SOPRALUCE/FIANCOLUCE FANLIGHT/SIDELIGHT	NO
ZOCOLO/FASCIA PARACOLPI BUMPER SKIRTING/BAND	SI / YES
CERNIERE A 3 ALI 3-FLAP HINGES	SI / YES ▫
MANIGLIERIA ANTIPANICO PANIC EXIT BAR	SI / YES
SERRATURA A 3 PUNTI DI CHIUSURA 3 LOCK POINTS LOCK	SI / YES
MANIGLIERIA CONFORME ALLE NORME DIN DIN COMPLIANT HANDLES	SI / YES
CONTROLLO ACCESSI ACCESS MONITORING	
SBLOCCO ELETTRICO ELECTRIC UNLOCK	SI / YES
ELETTROMANIGLIA ELECTROHANDLE	SI / YES
SERRATURA ELETTRICA ELECTRIC LOCK	SI / YES
ELETTROMAGNETI ELECTROMAGNETS	SI / YES
ELETTROBLOCCHI MAGNETICI MAGNETIC ELECTRIC BLOCKS	SI / YES
DIMENSIONI CERTIFICATE CERTIFIED DIMENSIONS (Per la disponibilità nella propria nazione, chiedere al ns ufficio tecnico) (Ask our technical assistance office for availability in your country)	
LARGHEZZA (LVM) WIDTH (LVM)	1150 ÷ 2300 (575 + 575) ÷ (1150 + 1150)
ALTEZZA (HVM) HEIGHT (HVM)	1987 ÷ 2650

CARATTERISTICHE PRESTAZIONALI STANDARD STANDARD PERFORMANCE FEATURES	
TRASMITTANZA TERMICA THERMAL TRANSMITTANCE	1,5 W/m²K
ABBATTIMENTO ACUSTICO NOISE REDUCTION	N.D.
DI SERIE STANDARD	
MANIGLIA + MANIGLIA CON SERRATURA ANTINCENDIO HANDLE + HANDLE WITH FIRE RESISTANT LOCK	
CERNIERE A VISTA EXPOSED HINGES	
PESO WEIGHT	30 kg/m²
CARATTERISTICHE PRESTAZIONALI SUPPLEMENTARI OPTIONAL PERFORMANCE FEATURES	
KIT FUMI FREDDI (S ₀) COLD FUMES KIT (S ₀)	NO
KIT FUMI CALDI (S _m /S ₂₀₀) HOT FUMES KIT (S _m /S ₂₀₀)	NO
ABBATTIMENTO ACUSTICO con soglia mobile NOISE REDUCTION with mobile threshold	NO
ABBATTIMENTO ACUSTICO con soglia fissa (uscita NON CONFORME alle uscite d'emergenza) NOISE REDUCTION with fixed threshold (this exit is NOT COMPLIANT with emergency exit requirements)	NO
PERMEABILITÀ ALL'ARIA E RESISTENZA AL CARICO DEL VENTO PERMEABILITY TO AIR AND RESISTANCE TO THE WIND LOAD	NO
PORTA PER ESTERNI EN 14351-1 * Abbinare sempre almeno la guarnizione di battuta EXTERNAL DOOR EN 14351-1 * Always match at least the door stop seal	SI / YES
VARIANTI SUPPLEMENTARI ADDITIONAL VARIATIONS	
FINISTRATURA RETTANGOLARE/OBLÒ (vedi limiti a pagina 22) SQUARE WINDOW / ROUND WINDOW (see limits on page 22)	SI / YES
SOPRALUCE/FIANCOLUCE FANLIGHT/SIDELIGHT	NO
ZOCCOLO/FASCIA PARACOLPI BUMPER SKIRTING/BAND	SI / YES
CERNIERE A 3 ALI 3-FLAP HINGES	SI / YES
MANIGLIERIA ANTIPANICO PANIC EXIT BAR	SI / YES
SERRATURA A 3 PUNTI DI CHIUSURA 3 LOCK POINTS LOCK	SI / YES
MANIGLIERIA CONFORME ALLE NORME DIN DIN COMPLIANT HANDLES	NO
CONTROLLO ACCESSI ACCESS MONITORING	
SBLOCCO ELETTRICO ELECTRIC UNLOCK	SI / YES
ELETTROMANIGLIA ELECTROHANDLE	SI / YES
SERRATURA ELETTRICA ELECTRIC LOCK	SI / YES
ELETTROMAGNETI ELECTROMAGNETS	SI / YES
ELETTROBLOCCHI MAGNETICI MAGNETIC ELECTRIC BLOCKS	SI / YES
DIMENSIONI CERTIFICATE CERTIFIED DIMENSIONS (Per la disponibilità nella propria nazione, chiedere al ns ufficio tecnico) (Ask our technical assistance office for availability in your country)	
LARGHEZZA (LVM) WIDTH (LVM)	500 ÷ 1350
ALTEZZA (HVM) HEIGHT (HVM)	1750 ÷ 2645

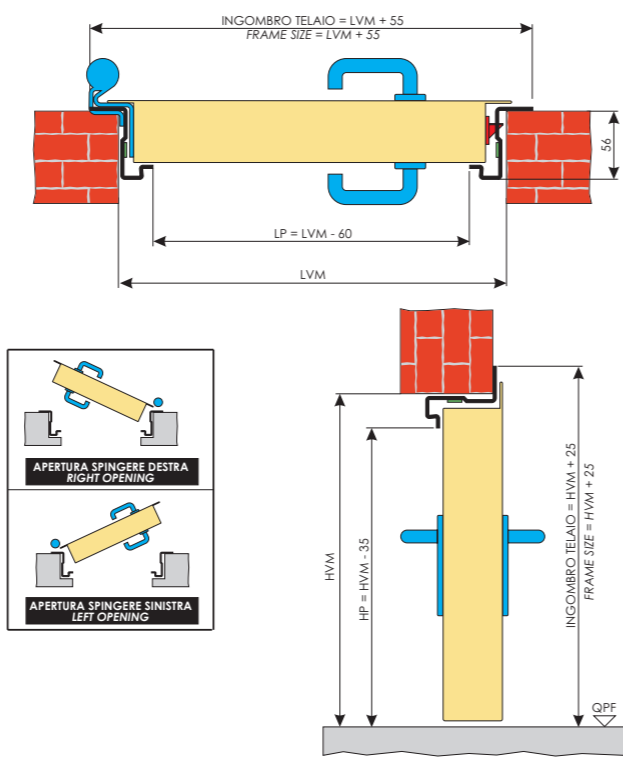

I disegni sono esemplificativi e fuori scala
Dierre si riserva il cambiamento della presente senza preavviso
Le quote sono espresse in millimetri

Drawing are examples and not in scale
Dierre holds the right to change this without notice
Dimensions are expressed in millimetres

* Per la compatibilità con i vari extra consultare il listino prezzi
For compatibility with the various extras refer to the price list

FINITURE FINISHINGS	
LACCATA RAL PER ESTERNI EXTERIOR RAL LACQUER	SI / YES
IN ACCIAIO INOX STAINLESS STEEL	NO
IN ACCIAIO PRERIVESTITO PRE-COATED STEEL	SI / YES
TIPOLOGIE DI MONTAGGIO MOUNTING SOLUTIONS	
CON ZANCHE WITH TIES	
SU CONTROTELAIO ON SUB-FRAME	
CON TASSELLI WITH BOLTS	
SU MAZZETTA ON REVEAL	

1,4 W/m²K

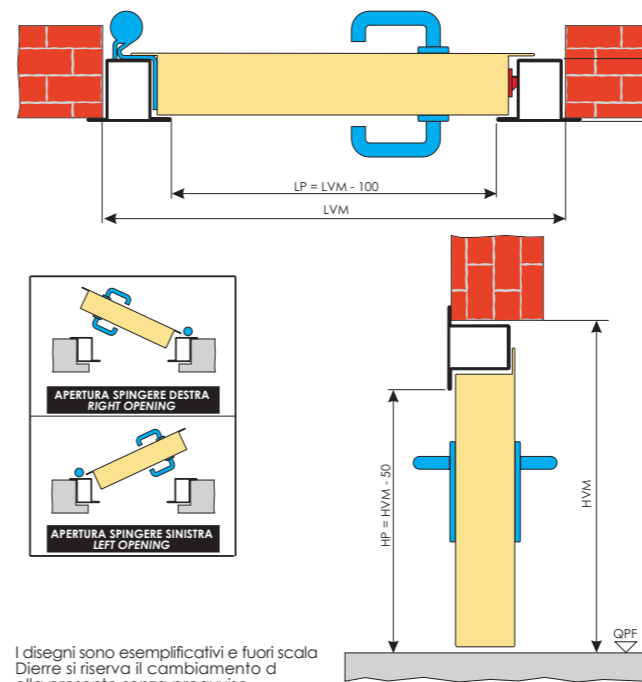
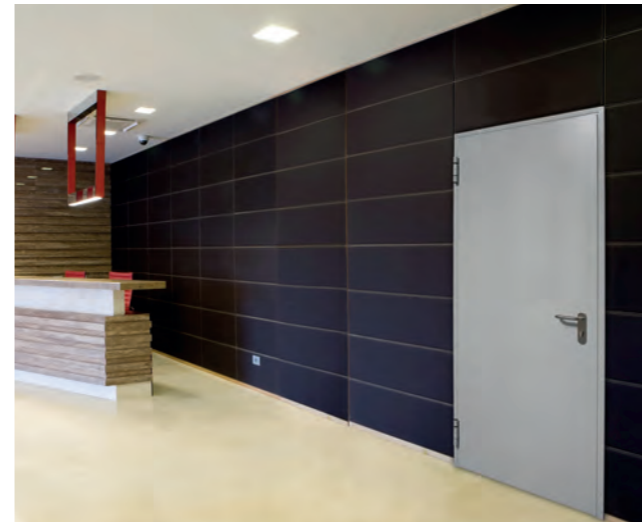



I disegni sono esemplificativi e fuori scala
Dierre si riserva il cambiamento della presente senza preavviso
Le quote sono espresse in millimetri

Drawing are examples and not in scale
Dierre holds the right to change this without notice
Dimensions are expressed in millimetres

* Per la compatibilità con i vari extra consultare il listino prezzi
For compatibility with the various extras refer to the price list

FINITURE FINISHINGS	
LACCATA RAL PER ESTERNI EXTERIOR RAL LACQUER	SI / YES
IN ACCIAIO INOX STAINLESS STEEL	NO
IN ACCIAIO PRERIVESTITO PRE-COATED STEEL	SI / YES
TIPOLOGIE DI MONTAGGIO MOUNTING SOLUTIONS	
CON ZANCHE WITH TIES	
CON TASSELLI WITH BOLTS	
TIPOLOGIE DI TELAIO TYPES OF FRAME	
A "Z" SHAPED	
A "T" SHAPED	
A "L" SHAPED	

CARATTERISTICHE PRESTAZIONALI STANDARD STANDARD PERFORMANCE FEATURES	
TRASMITTANZA TERMICA THERMAL TRANSMITTANCE	1,5 W/m²K
ABBATTIMENTO ACUSTICO NOISE REDUCTION	N.D.
DI SERIE STANDARD	
MANIGLIA + MANIGLIA CON SERRATURA ANTINCENDIO HANDLE + HANDLE WITH FIRE RESISTANT LOCK	
CERNIERE A VISTA EXPOSED HINGES	
PESO WEIGHT	30 kg/m²
CARATTERISTICHE PRESTAZIONALI SUPPLEMENTARI OPTIONAL PERFORMANCE FEATURES	
KIT FUMI FREDDI (S ₀) COLD FUMES KIT (S ₀)	NO
KIT FUMI CALDI (S _m /S ₂₀₀) HOT FUMES KIT (S _m /S ₂₀₀)	NO
ABBATTIMENTO ACUSTICO con soglia mobile NOISE REDUCTION with mobile threshold	NO
ABBATTIMENTO ACUSTICO con soglia fissa (uscita NON CONFORME alle uscite d'emergenza) NOISE REDUCTION with fixed threshold (this exit is NOT COMPLIANT with emergency exit requirements)	NO
PERMEABILITÀ ALL'ARIA E RESISTENZA AL CARICO DEL VENTO PERMEABILITY TO AIR AND RESISTANCE TO THE WIND LOAD	NO
PORTA PER ESTERNI EN 14351-1 * Abbinare sempre almeno la guarnizione di battuta EXTERNAL DOOR EN 14351-1 * Always match at least the door stop seal	SI / YES
VARIANTI SUPPLEMENTARI ADDITIONAL VARIATIONS	
FINISTRATURA RETTANGOLARE/OBLÒ (vedi limiti a pagina 22) SQUARE WINDOW / ROUND WINDOW (see limits on page 22)	SI / YES
SOPRALUCE/FIANCOLUCE FANLIGHT/SIDELIGHT	NO
ZOCCOLO/FASCIA PARACOLPI BUMPER SKIRTING/BAND	SI / YES
CERNIERE A 3 ALI 3-FLAP HINGES	NO
MANIGLIERIA ANTIPANICO PANIC EXIT BAR	SI / YES
SERRATURA A 3 PUNTI DI CHIUSURA 3 LOCK POINTS LOCK	SI / YES
MANIGLIERIA CONFORME ALLE NORME DIN DIN COMPLIANT HANDLES	NO
CONTROLLO ACCESSI ACCESS MONITORING	
SBLOCCO ELETTRICO ELECTRIC UNLOCK	SI / YES
ELETTROMANIGLIA ELECTROHANDLE	SI / YES
SERRATURA ELETTRICA ELECTRIC LOCK	SI / YES
ELETTROMAGNETI ELECTROMAGNETS	SI / YES
ELETTROBLOCCHI MAGNETICI MAGNETIC ELECTRIC BLOCKS	SI / YES
DIMENSIONI CERTIFICATE CERTIFIED DIMENSIONS (Per la disponibilità nella propria nazione, chiedere al ns ufficio tecnico) (Ask our technical assistance office for availability in your country)	
LARGHEZZA (LVM) WIDTH (LVM)	520 ÷ 1140
ALTEZZA (HVM) HEIGHT (HVM)	1730 ÷ 2640



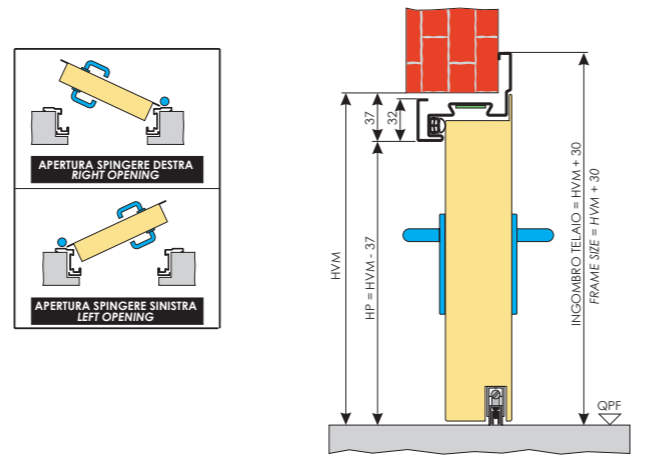
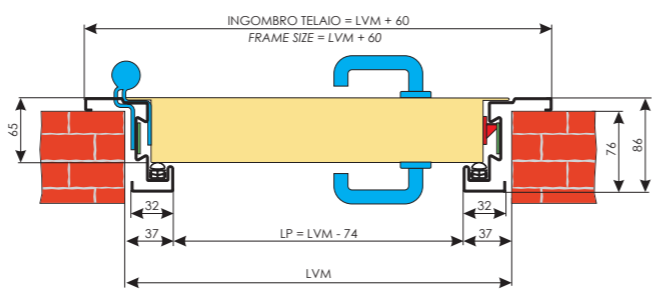

CARATTERISTICHE PRESTAZIONALI STANDARD STANDARD PERFORMANCE FEATURES	
TRASMITTANZA TERMICA THERMAL TRANSMITTANCE	1,6 W/m²K
ABBATTIMENTO ACUSTICO con soglia mobile NOISE REDUCTION with mobile threshold	38 dB
DI SERIE STANDARD	
MANIGLIA + MANIGLIA CON SERRATURA ANTINCENDIO HANDLE + HANDLE WITH FIRE RESISTANT LOCK	
CERNIERE A VISTA EXPOSED HINGES	
PESO WEIGHT	55 kg/m²
CARATTERISTICHE PRESTAZIONALI SUPPLEMENTARI OPTIONAL PERFORMANCE FEATURES	
KIT FUMI FREDDI (S ₂) COLD FUMES KIT (S ₂)	NO
KIT FUMI CALDI (S _m /S ₂₀₀) HOT FUMES KIT (S _m /S ₂₀₀)	NO
PERMEABILITÀ ALL'ARIA E RESISTENZA AL CARICO DEL VENTO PERMEABILITY TO AIR AND RESISTANCE TO THE WIND LOAD	NO
PORTA PER ESTERNI EN 14351-1 * EXTERNAL DOOR EN 14351-1 *	SI / YES
VARIANTI SUPPLEMENTARI ADDITIONAL VARIATIONS	
FINISTRATURA RETTANGOLARE/OBLÒ (vedi limiti a pagina 22) SQUARE WINDOW / ROUND WINDOW (see limits on page 22)	NO
SOPRALUCE/FIANCOLUCE FANLIGHT/SIDE LIGHT	NO
ZOCCOLO/FASCIA PARACOLPI BUMPER SKIRTING/BAND	SI / YES
CERNIERE A 3 ALI 3-FLAP HINGES	SI / YES
MANIGLIERIA ANTIPANICO PANIC EXIT BAR	SI / YES
SERRATURA A 3 PUNTI DI CHIUSURA 3 LOCK POINTS LOCK	SI / YES
MANIGLIERIA CONFORME ALLE NORME DIN DIN COMPLIANT HANDLES	SI / YES
CONTROLLO ACCESSI ACCESS MONITORING	
SBLOCCO ELETTRICO ELECTRIC UNLOCK	SI / YES
ELETTROMANIGLIA ELECTROHANDLE	SI / YES
SERRATURA ELETTRICA ELECTRIC LOCK	SI / YES
ELETTROMAGNETI ELECTROMAGNETS	SI / YES
ELETTROBLOCCHI MAGNETICI MAGNETIC ELECTRIC BLOCKS	SI / YES
DIMENSIONI CERTIFICATE (Per la disponibilità nella propria nazione, chiedere al ns ufficio tecnico) CERTIFIED DIMENSIONS (Ask our technical assistance office for availability in your country)	
LARGHEZZA (LVM) WIDTH (LVM)	750 ÷ 1350
ALTEZZA (HVM) HEIGHT (HVM)	2000 ÷ 2650



I disegni sono esemplificativi e fuori scala
Dierre si riserva il cambiamento della presente senza preavviso
Le quote sono espresse in millimetri

Drawing are examples and not in scale
Dierre holds the right to change this without notice
Dimensions are expressed in millimetres

* Per la compatibilità con i vari extra consultare il listino prezzi
For compatibility with the various extras refer to the price list



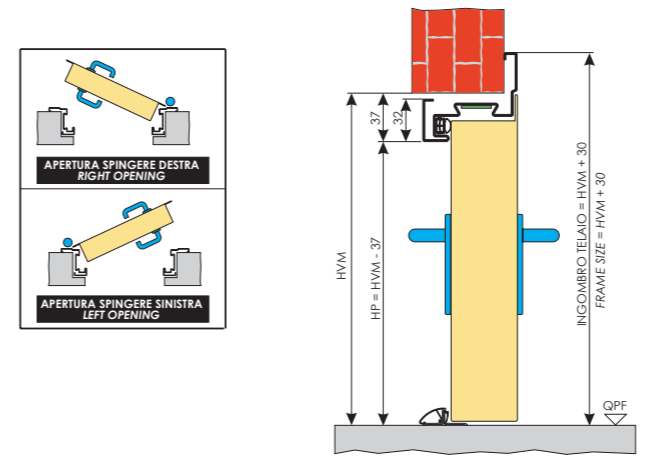
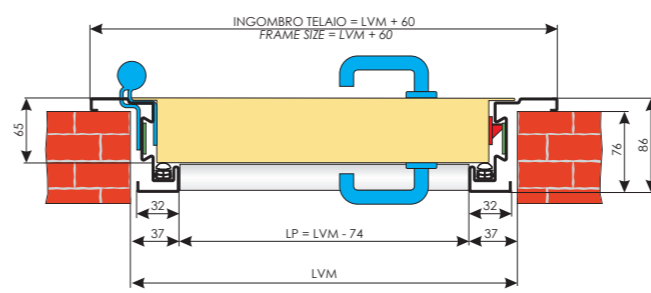

FINITURE FINISHINGS	
LACCATA RAL PER ESTERNI EXTERIOR RAL LACQUER	SI / YES
IN ACCIAIO INOX STAINLESS STEEL	SI / YES
IN ACCIAIO PRERIVESTITO PRE-COATED STEEL	SI / YES
TIPOLOGIE DI MONTAGGIO MOUNTING SOLUTIONS	
CON ZANCHE WITH TIES	
SU CONTROTELAIO ON SUB-FRAME	
CON TASSELLI WITH BOLTS	
SU MAZZETTA ON REVEAL	



I disegni sono esemplificativi e fuori scala
Dierre si riserva il cambiamento della presente senza preavviso
Le quote sono espresse in millimetri

Drawing are examples and not in scale
Dierre holds the right to change this without notice
Dimensions are expressed in millimetres

* Per la compatibilità con i vari extra consultare il listino prezzi
For compatibility with the various extras refer to the price list



FINITURE FINISHINGS	
LACCATA RAL PER ESTERNI EXTERIOR RAL LACQUER	SI / YES
IN ACCIAIO INOX STAINLESS STEEL	SI / YES
IN ACCIAIO PRERIVESTITO PRE-COATED STEEL	SI / YES
TIPOLOGIE DI MONTAGGIO MOUNTING SOLUTIONS	
CON ZANCHE WITH TIES	
SU CONTROTELAIO ON SUB-FRAME	
CON TASSELLI WITH BOLTS	
SU MAZZETTA ON REVEAL	

CARATTERISTICHE PRESTAZIONALI STANDARD STANDARD PERFORMANCE FEATURES	
TRASMITTANZA TERMICA THERMAL TRANSMITTANCE	1,6 W/m²K
ABBATTIMENTO ACUSTICO con soglia fissa (uscita NON CONFORME alle uscite d'emergenza) NOISE REDUCTION with fixed threshold (this exit is NOT COMPLIANT with emergency exit requirements)	42 dB
DI SERIE STANDARD	
MANIGLIA + MANIGLIA CON SERRATURA ANTINCENDIO HANDLE + HANDLE WITH FIRE RESISTANT LOCK	
CERNIERE A VISTA EXPOSED HINGES	
PESO WEIGHT	55 kg/m²
CARATTERISTICHE PRESTAZIONALI SUPPLEMENTARI OPTIONAL PERFORMANCE FEATURES	
KIT FUMI FREDDI (S ₂) COLD FUMES KIT (S ₂)	NO
KIT FUMI CALDI (S _m /S ₂₀₀) HOT FUMES KIT (S _m /S ₂₀₀)	NO
PERMEABILITÀ ALL'ARIA E RESISTENZA AL CARICO DEL VENTO PERMEABILITY TO AIR AND RESISTANCE TO THE WIND LOAD	NO
PORTA PER ESTERNI EN 14351-1 * EXTERNAL DOOR EN 14351-1 *	SI / YES
VARIANTI SUPPLEMENTARI ADDITIONAL VARIATIONS	
FINISTRATURA RETTANGOLARE/OBLÒ (vedi limiti a pagina 22) SQUARE WINDOW / ROUND WINDOW (see limits on page 22)	NO
SOPRALUCE/FIANCOLUCE FANLIGHT/SIDE LIGHT	NO
ZOCCOLO/FASCIA PARACOLPI BUMPER SKIRTING/BAND	SI / YES
CERNIERE A 3 ALI 3-FLAP HINGES	SI / YES
MANIGLIERIA ANTIPANICO PANIC EXIT BAR	SI / YES
SERRATURA A 3 PUNTI DI CHIUSURA 3 LOCK POINTS LOCK	SI / YES
MANIGLIERIA CONFORME ALLE NORME DIN DIN COMPLIANT HANDLES	SI / YES
CONTROLLO ACCESSI ACCESS MONITORING	
SBLOCCO ELETTRICO ELECTRIC UNLOCK	SI / YES
ELETTROMANIGLIA ELECTROHANDLE	SI / YES
SERRATURA ELETTRICA ELECTRIC LOCK	SI / YES
ELETTROMAGNETI ELECTROMAGNETS	SI / YES
ELETTROBLOCCHI MAGNETICI MAGNETIC ELECTRIC BLOCKS	SI / YES
DIMENSIONI CERTIFICATE (Per la disponibilità nella propria nazione, chiedere al ns ufficio tecnico) CERTIFIED DIMENSIONS (Ask our technical assistance office for availability in your country)	
LARGHEZZA (LVM) WIDTH (LVM)	750 ÷ 1350
ALTEZZA (HVM) HEIGHT (HVM)	2000 ÷ 2650

CARATTERISTICHE PRESTAZIONALI STANDARD
STANDARD PERFORMANCE FEATURES

TRASMITTANZA TERMICA THERMAL TRANSMITTANCE		1,4 W/m² K
ANTIEFFRAZIONE BURGLAR RESISTANCE		classe 2
DI SERIE STANDARD		
MANIGLIA + MANIGLIA CON SERRATURA ANTINCENDIO HANDLE + HANDLE WITH FIRE RESISTANT LOCK		
CERNIERE A VISTA EXPOSED HINGES		
SERRATURA A 3 PUNTI DI CHIUSURA 3 LOCK POINTS LOCK		
PESO WEIGHT		40 kg/m²

CARATTERISTICHE PRESTAZIONALI SUPPLEMENTARI
OPTIONAL PERFORMANCE FEATURES

KIT FUMI FREDDI (S ₀) COLD FUMES KIT (S ₀) KIT FUMI CALDI (S _m /S ₂₀₀) HOT FUMES KIT (S _m /S ₂₀₀)		SI / YES
PERMEABILITÀ ALL'ARIA E RESISTENZA AL CARICO DEL VENTO PERMEABILITY TO AIR AND RESISTANCE TO THE WIND LOAD		NO
PORTA PER ESTERNI EN 14351-1 * Abbinare sempre almeno la guarnizione di battuta EXTERNAL DOOR EN 14351-1 * Always match at least the door stop seal		SI / YES

VARIANTI SUPPLEMENTARI
ADDITIONAL VARIATIONS

FINISTRATURA RETTANGOLARE/OBLÒ (vedi limiti a pagina 22) SQUARE WINDOW / ROUND WINDOW (see limits on page 22)		NO
SOPRALUCE/FIANCOLUCE FANLIGHT/SIDELIGHT		NO
ZOCCOLO/FASCIA PARACOLPI BUMPER SKIRTING/BAND		SI / YES
CERNIERE A 3 ALI 3-FLAP HINGES		NO
MANIGLIERA ANTIPANICO PANIC EXIT BAR		SI / YES
SERRATURA A 3 PUNTI DI CHIUSURA 3 LOCK POINTS LOCK		SI / YES
MANIGLIERA CONFORME ALLE NORME DIN DIN COMPLIANT HANDLES		SI / YES

CONTROLLO ACCESSI
ACCESS MONITORING

SBLOCCO ELETTRICO ELECTRIC UNLOCK		NO
ELETTROMANIGLIA ELECTROHANDLE		NO
SERRATURA ELETTRICA ELECTRIC LOCK		NO
ELETTROMAGNETI ELECTROMAGNETS		SI / YES
ELETTROBLOCCHI MAGNETICI MAGNETIC ELECTRIC BLOCKS		SI / YES

DIMENSIONI CERTIFICATE (Per la disponibilità nella propria nazione, chiedere al ns ufficio tecnico)
CERTIFIED DIMENSIONS (Ask our technical assistance office for availability in your country)

LARGHEZZA (LVM) WIDTH (LVM)		800 ÷ 1100
ALTEZZA (HVM) HEIGHT (HVM)		1987 ÷ 2365

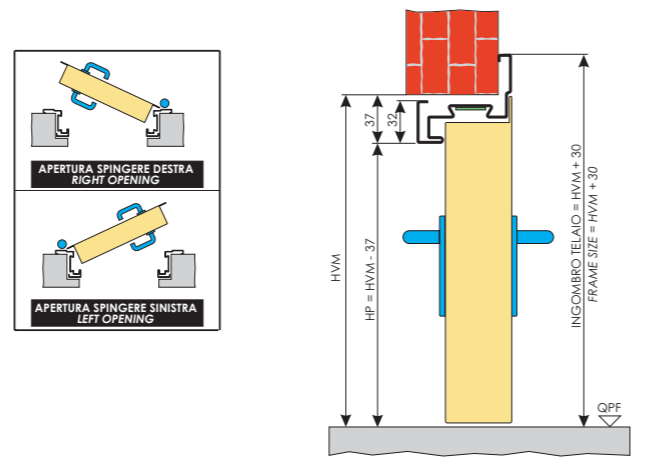
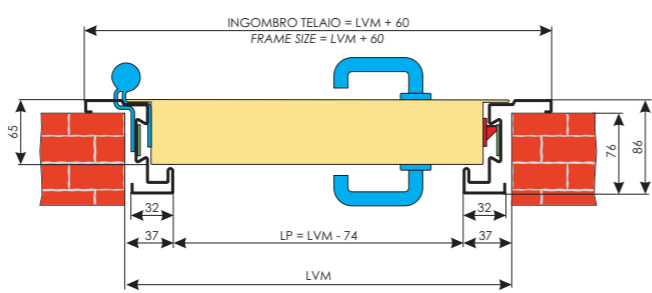

I disegni sono esemplificativi e fuori scala
Dierre si riserva il cambiamento della presente senza preavviso
Le quote sono espresse in millimetri



Drawing are examples and not in scale
Dierre holds the right to change this without notice
Dimensions are expressed in millimetres

* Per la compatibilità con i vari extra consultare il listino prezzi
For compatibility with the various extras refer to the price list

FINITURE
FINISHINGS

LACCATA RAL PER ESTERNI EXTERIOR RAL LACQUER		SI / YES
IN ACCIAIO INOX STAINLESS STEEL		NO
IN ACCIAIO PRERIVESTITO PRE-COATED STEEL		SI / YES

TIPOLOGIE DI MONTAGGIO
MOUNTING SOLUTIONS

CON ZANCHE WITH TIES	
SU CONTROTELAIO ON SUB-FRAME	
CON TASSELLI WITH BOLTS	

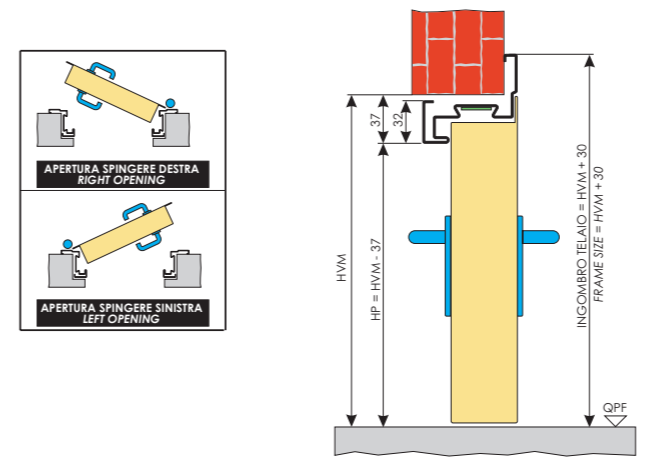
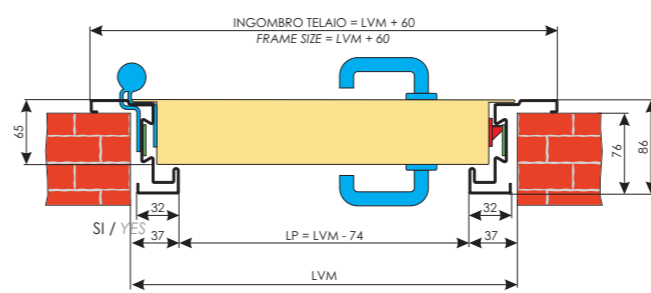

I disegni sono esemplificativi e fuori scala
Dierre si riserva il cambiamento della presente senza preavviso
Le quote sono espresse in millimetri



Drawing are examples and not in scale
Dierre holds the right to change this without notice
Dimensions are expressed in millimetres

* Per la compatibilità con i vari extra consultare il listino prezzi
For compatibility with the various extras refer to the price list

FINITURE
FINISHINGS

LACCATA RAL PER ESTERNI EXTERIOR RAL LACQUER		SI / YES
IN ACCIAIO INOX STAINLESS STEEL		NO
IN ACCIAIO PRERIVESTITO PRE-COATED STEEL		SI / YES



TIPOLOGIE DI MONTAGGIO
MOUNTING SOLUTIONS

CON ZANCHE WITH TIES	
SU CONTROTELAIO ON SUB-FRAME	
CON TASSELLI WITH BOLTS	

CARATTERISTICHE PRESTAZIONALI STANDARD
STANDARD PERFORMANCE FEATURES

TRASMITTANZA TERMICA THERMAL TRANSMITTANCE		1,6 W/m² K
ANTIEFFRAZIONE BURGLAR RESISTANCE		classe 3
DI SERIE STANDARD		
MANIGLIA + MANIGLIA CON DEFENDER ANTIPANICO HANDLE + HANDLE WITH ANTIPANIC DEFENDER		
CERNIERE A VISTA EXPOSED HINGES		
SERRATURA A 3 PUNTI DI CHIUSURA 3 LOCK POINTS LOCK		
PESO WEIGHT		55 kg/m²

CARATTERISTICHE PRESTAZIONALI SUPPLEMENTARI
OPTIONAL PERFORMANCE FEATURES

KIT FUMI FREDDI (S ₀) COLD FUMES KIT (S ₀) KIT FUMI CALDI (S _m /S ₂₀₀) HOT FUMES KIT (S _m /S ₂₀₀)		SI / YES
PERMEABILITÀ ALL'ARIA E RESISTENZA AL CARICO DEL VENTO PERMEABILITY TO AIR AND RESISTANCE TO THE WIND LOAD		NO
PORTA PER ESTERNI EN 14351-1 * Abbinare sempre almeno la guarnizione di battuta EXTERNAL DOOR EN 14351-1 * Always match at least the door stop seal		SI / YES

VARIANTI SUPPLEMENTARI
ADDITIONAL VARIATIONS

FINISTRATURA RETTANGOLARE/OBLÒ (vedi limiti a pagina 22) SQUARE WINDOW / ROUND WINDOW (see limits on page 22)		NO
SOPRALUCE/FIANCOLUCE FANLIGHT/SIDELIGHT		NO
ZOCCOLO/FASCIA PARACOLPI BUMPER SKIRTING/BAND		SI / YES
CERNIERE A 3 ALI 3-FLAP HINGES		NO
MANIGLIERA ANTIPANICO PANIC EXIT BAR		SI / YES
SERRATURA A 3 PUNTI DI CHIUSURA 3 LOCK POINTS LOCK		NO
MANIGLIERA CONFORME ALLE NORME DIN DIN COMPLIANT HANDLES		SI / YES

CONTROLLO ACCESSI
ACCESS MONITORING

SBLOCCO ELETTRICO ELECTRIC UNLOCK		NO
ELETTROMANIGLIA ELECTROHANDLE		NO
SERRATURA ELETTRICA ELECTRIC LOCK		NO
ELETTROMAGNETI ELECTROMAGNETS		SI / YES
ELETTROBLOCCHI MAGNETICI MAGNETIC ELECTRIC BLOCKS		SI / YES

DIMENSIONI CERTIFICATE (Per la disponibilità nella propria nazione, chiedere al ns ufficio tecnico)
CERTIFIED DIMENSIONS (Ask our technical assistance office for availability in your country)

LARGHEZZA (LVM) WIDTH (LVM)		800 ÷ 1100
ALTEZZA (HVM) HEIGHT (HVM)		1987 ÷ 2365

CARATTERISTICHE PRESTAZIONALI STANDARD STANDARD PERFORMANCE FEATURES	
TRASMITTANZA TERMICA THERMAL TRANSMITTANCE	1,4 W/m²K
ABBATTIMENTO ACUSTICO NOISE REDUCTION	19 dB
DI SERIE STANDARD	
MANIGLIA + MANIGLIA CON SERRATURA ANTINCENDIO HANDLE + HANDLE WITH FIRE RESISTANT LOCK	
CERNIERE A 3 ALI 3-FLAP HINGES	
PESO WEIGHT	35 kg/m²

CARATTERISTICHE PRESTAZIONALI SUPPLEMENTARI OPTIONAL PERFORMANCE FEATURES	
KIT FUMI FREDDI (S ₀) COLD FUMES KIT (S ₀) KIT FUMI CALDI (S _m /S ₂₀₀) HOT FUMES KIT (S _m /S ₂₀₀)	SI / YES
ABBATTIMENTO ACUSTICO con soglia mobile NOISE REDUCTION with mobile threshold	27 dB
ABBATTIMENTO ACUSTICO con soglia fissa (uscita NON CONFORME alle uscite d'emergenza) NOISE REDUCTION with fixed threshold (this exit is NOT COMPLIANT with emergency exit requirements)	34 dB
PERMEABILITÀ ALL'ARIA E RESISTENZA AL CARICO DEL VENTO PERMEABILITY TO AIR AND RESISTANCE TO THE WIND LOAD	classe 4 C4
PORTA PER ESTERNI EN 14351-1 * Abbinare sempre almeno la guarnizione di battuta EXTERNAL DOOR EN 14351-1 * Always match at least the door stop seal	CE SI / YES

VARIANTI SUPPLEMENTARI ADDITIONAL VARIATIONS	
FINISTRATURA RETTANGOLARE/OBLÒ (vedi limiti a pagina 22) SQUARE WINDOW / ROUND WINDOW (see limits on page 22)	SI / YES
SOPRALUCE/FIANCOLUCE FANLIGHT/SIDELIGHT	NO
ZOCOLO/FASCIA PARACOLPI BUMPER SKIRTING/BAND	SI / YES
CERNIERE A 3 ALI 3-FLAP HINGES	NO
MANIGLIERIA ANTIPANICO PANIC EXIT BAR SI / YES	SI / YES
SERRATURA A 3 PUNTI DI CHIUSURA 3 LOCK POINTS LOCK	SI / YES
MANIGLIERIA CONFORME ALLE NORME DIN DIN COMPLIANT HANDLES	SI / YES



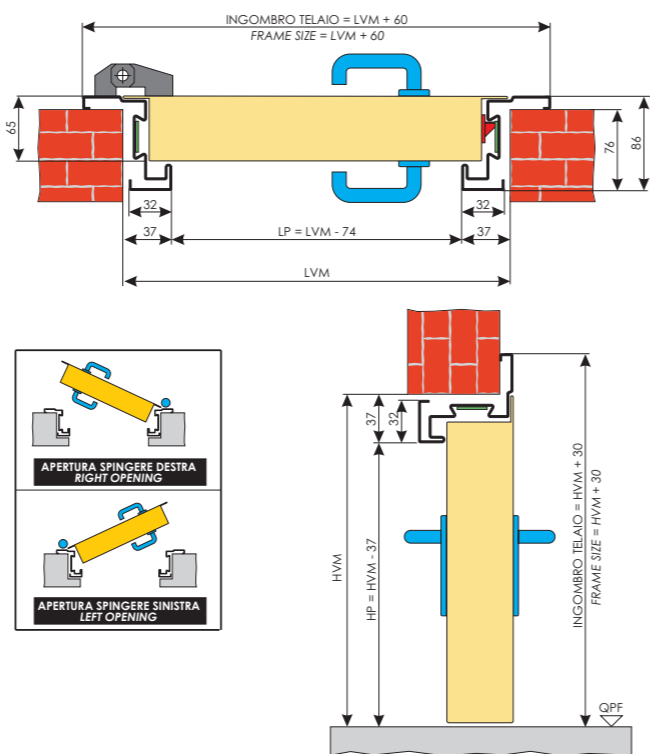

CONTROLLO ACCESSI ACCESS MONITORING	
SBLOCCO ELETTRICO ELECTRIC UNLOCK	SI / YES
ELETTROMANIGLIA ELECTROHANDLE	SI / YES
SERRATURA ELETTRICA ELECTRIC LOCK	SI / YES
ELETTROMAGNETI ELECTROMAGNETS	SI / YES
ELETTROBLOCCHI MAGNETICI MAGNETIC ELECTRIC BLOCKS	SI / YES
DIMENSIONI CERTIFICATE CERTIFIED DIMENSIONS (Per la disponibilità nella propria nazione, chiedere al ns ufficio tecnico) (Ask our technical assistance office for availability in your country)	
LARGHEZZA (LVM) WIDTH (LVM)	675 ÷ 1350
ALTEZZA (HVM) HEIGHT (HVM)	1987 ÷ 2650



I disegni sono esemplificativi e fuori scala
Dierre si riserva il cambiamento della presente senza preavviso
Le quote sono espresse in millimetri

Drawing are examples and not in scale
Dierre holds the right to change this without notice
Dimensions are expressed in millimetres

* Per la compatibilità con i vari extra consultare il listino prezzi
For compatibility with the various extras refer to the price list



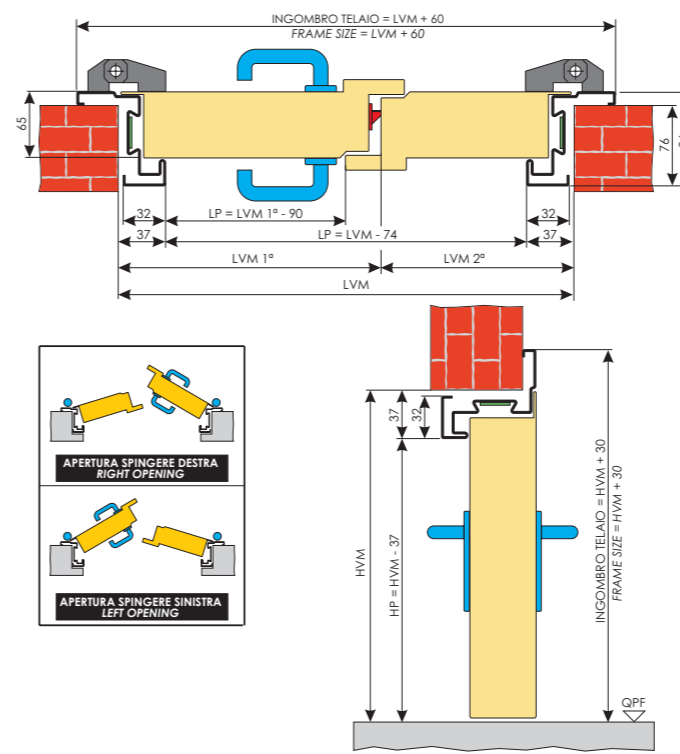

FINITURE FINISHINGS	
LACCATA RAL PER ESTERNI EXTERIOR RAL LACQUER	SI / YES
IN ACCIAIO INOX STAINLESS STEEL	NO
IN ACCIAIO PRERIVESTITO PRE-COATED STEEL	SI / YES
TIPOLOGIE DI MONTAGGIO MOUNTING SOLUTIONS	
CON ZANCHE WITH TIES	
SU CONTROTELAIO ON SUB-FRAME	
CON TASSELLI WITH BOLTS	
SU MAZZETTA ON REVEAL	



I disegni sono esemplificativi e fuori scala
Dierre si riserva il cambiamento della presente senza preavviso
Le quote sono espresse in millimetri

Drawing are examples and not in scale
Dierre holds the right to change this without notice
Dimensions are expressed in millimetres

* Per la compatibilità con i vari extra consultare il listino prezzi
For compatibility with the various extras refer to the price list

FINITURE FINISHINGS	
LACCATA RAL PER ESTERNI EXTERIOR RAL LACQUER	SI / YES
IN ACCIAIO INOX STAINLESS STEEL	NO
IN ACCIAIO PRERIVESTITO PRE-COATED STEEL	SI / YES
TIPOLOGIE DI MONTAGGIO MOUNTING SOLUTIONS	
CON ZANCHE WITH TIES	
SU CONTROTELAIO ON SUB-FRAME	
CON TASSELLI WITH BOLTS	
SU MAZZETTA ON REVEAL	

CARATTERISTICHE PRESTAZIONALI STANDARD STANDARD PERFORMANCE FEATURES	
TRASMITTANZA TERMICA THERMAL TRANSMITTANCE	1,7 W/m²K
ABBATTIMENTO ACUSTICO NOISE REDUCTION	19 dB
DI SERIE STANDARD	
MANIGLIA + MANIGLIA CON SERRATURA ANTINCENDIO HANDLE + HANDLE WITH FIRE RESISTANT LOCK	
CERNIERE A 3 ALI 3-FLAP HINGES	
PESO WEIGHT	35 kg/m²

CARATTERISTICHE PRESTAZIONALI SUPPLEMENTARI OPTIONAL PERFORMANCE FEATURES	
KIT FUMI FREDDI (S ₀) COLD FUMES KIT (S ₀) KIT FUMI CALDI (S _m /S ₂₀₀) HOT FUMES KIT (S _m /S ₂₀₀)	SI / YES
ABBATTIMENTO ACUSTICO con soglia mobile NOISE REDUCTION with mobile threshold	25 dB
ABBATTIMENTO ACUSTICO con soglia fissa (uscita NON CONFORME alle uscite d'emergenza) NOISE REDUCTION with fixed threshold (this exit is NOT COMPLIANT with emergency exit requirements)	30 dB
PERMEABILITÀ ALL'ARIA E RESISTENZA AL CARICO DEL VENTO PERMEABILITY TO AIR AND RESISTANCE TO THE WIND LOAD	classe 4 C4
PORTA PER ESTERNI EN 14351-1 * Abbinare sempre almeno la guarnizione di battuta EXTERNAL DOOR EN 14351-1 * Always match at least the door stop seal	CE SI / YES

VARIANTI SUPPLEMENTARI ADDITIONAL VARIATIONS	
FINISTRATURA RETTANGOLARE/OBLÒ (vedi limiti a pagina 22) SQUARE WINDOW / ROUND WINDOW (see limits on page 22)	SI / YES
SOPRALUCE/FIANCOLUCE FANLIGHT/SIDELIGHT	SI / YES
ZOCOLO/FASCIA PARACOLPI BUMPER SKIRTING/BAND	SI / YES
CERNIERE A 3 ALI 3-FLAP HINGES	NO
MANIGLIERIA ANTIPANICO PANIC EXIT BAR	SI / YES
SERRATURA A 3 PUNTI DI CHIUSURA 3 LOCK POINTS LOCK	SI / YES
MANIGLIERIA CONFORME ALLE NORME DIN DIN COMPLIANT HANDLES	SI / YES

CONTROLLO ACCESSI ACCESS MONITORING	
SBLOCCO ELETTRICO ELECTRIC UNLOCK	SI / YES
ELETTROMANIGLIA ELECTROHANDLE	SI / YES
SERRATURA ELETTRICA ELECTRIC LOCK	SI / YES
ELETTROMAGNETI ELECTROMAGNETS	SI / YES
ELETTROBLOCCHI MAGNETICI MAGNETIC ELECTRIC BLOCKS	SI / YES
DIMENSIONI CERTIFICATE CERTIFIED DIMENSIONS (Per la disponibilità nella propria nazione, chiedere al ns ufficio tecnico) (Ask our technical assistance office for availability in your country)	
LARGHEZZA (LVM) WIDTH (LVM)	950 ÷ 2600 (600 + 350) ÷ (1300 + 1300)
ALTEZZA (HVM) HEIGHT (HVM)	1987 ÷ 2650

CARATTERISTICHE PRESTAZIONALI STANDARD
STANDARD PERFORMANCE FEATURES

TRASMITTANZA TERMICA THERMAL TRANSMITTANCE		1,4 W/m²K
---	---	-----------

ABBATTIMENTO ACUSTICO NOISE REDUCTION		19 dB
--	---	-------

DI SERIE STANDARD

MANIGLIA + MANIGLIA CON SERRATURA ANTINCENDIO HANDLE + HANDLE WITH FIRE RESISTANT LOCK		
---	---	--

CERNIERE NASCOSTE CONCEALED HINGES		
---------------------------------------	---	--

PESO WEIGHT		40 kg/m²
----------------	--	----------

CARATTERISTICHE PRESTAZIONALI SUPPLEMENTARI
OPTIONAL PERFORMANCE FEATURES

KIT FUMI FREDDI (S ₂₀) COLD FUMES KIT (S ₂₀) KIT FUMI CALDI (S _m /S ₂₀₀) HOT FUMES KIT (S _m /S ₂₀₀)		NO
--	---	----

ABBATTIMENTO ACUSTICO con soglia mobile NOISE REDUCTION with mobile threshold		27 dB
--	---	-------

ABBATTIMENTO ACUSTICO con soglia fissa (uscita NON CONFORME alle uscite d'emergenza) NOISE REDUCTION with fixed threshold (this exit is NOT COMPLIANT with emergency exit requirements)		34 dB
--	---	-------

PERMEABILITÀ ALL'ARIA E RESISTENZA AL CARICO DEL VENTO PERMEABILITY TO AIR AND RESISTANCE TO THE WIND LOAD		classe 4 C4
---	---	----------------

PORTA PER ESTERNI EN 14351-1 * Abbinare sempre almeno la guarnizione di battuta EXTERNAL DOOR EN 14351-1 * Always match at least the door stop seal		SI / YES
--	--	----------

VARIANTI SUPPLEMENTARI
ADDITIONAL VARIATIONS

FINISTRATURA RETTANGOLARE/OBLÒ (vedi limiti a pagina 22) SQUARE WINDOW / ROUND WINDOW (see limits on page 22)		SI / YES
--	---	----------

SOPRALUCE/FIANCOLUCE FANLIGHT/SIDELIGHT		NO
--	---	----

ZOCOLO/FASCIA PARACOLPI BUMPER SKIRTING/BAND		SI / YES
---	---	----------

CERNIERE A 3 ALI 3-FLAP HINGES		NO
-----------------------------------	---	----

MANIGLIERIA ANTIPANICO PANIC EXIT BAR		SI / YES
--	---	----------

SERRATURA A 3 PUNTI DI CHIUSURA 3 LOCK POINTS LOCK		SI / YES
---	---	----------

MANIGLIERIA CONFORME ALLE NORME DIN DIN COMPLIANT HANDLES		SI / YES
--	--	----------

CONTROLLO ACCESSI
ACCESS MONITORING

SBLOCCO ELETTRICO ELECTRIC UNLOCK		SI / YES
--------------------------------------	--	----------

ELETTROMANIGLIA ELECTROHANDLE		SI / YES
----------------------------------	--	----------

SERRATURA ELETTRICA ELECTRIC LOCK		SI / YES
--------------------------------------	--	----------

ELETTROMAGNETI ELECTROMAGNETS		SI / YES
----------------------------------	--	----------

ELETTROBLOCCHI MAGNETICI MAGNETIC ELECTRIC BLOCKS		SI / YES
--	--	----------

DIMENSIONI CERTIFICATE
CERTIFIED DIMENSIONS (Per la disponibilità nella propria nazione, chiedere al ns ufficio tecnico)
(Ask our technical assistance office for availability in your country)

LARGHEZZA (LVM) WIDTH (LVM)		675 ÷ 1350
--------------------------------	--	------------

ALTEZZA (HVM) HEIGHT (HVM)		1987 ÷ 2300
-------------------------------	--	-------------

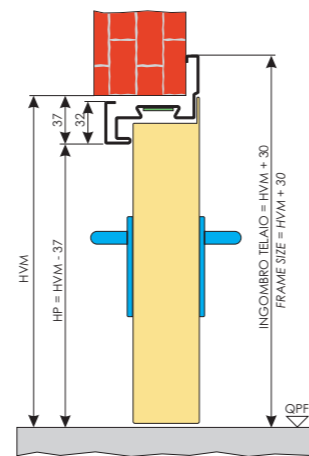
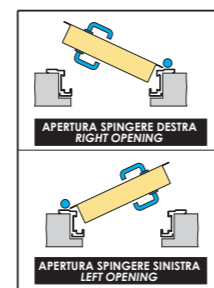
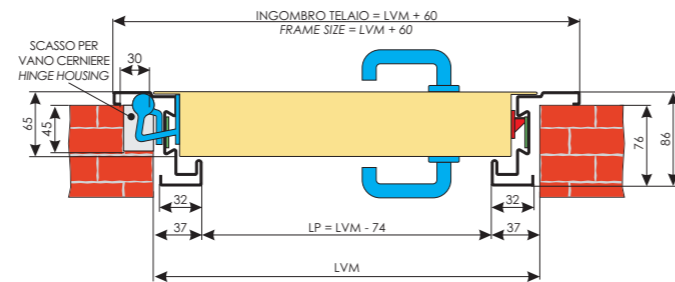

I disegni sono esemplificativi e fuori scala
Dierre si riserva il cambiamento della presente senza preavviso
Le quote sono espresse in millimetri

Drawing are examples and not in scale
Dierre holds the right to change this without notice
Dimensions are expressed in millimetres

* Per la compatibilità con i vari extra consultare il listino prezzi
For compatibility with the various extras refer to the price list

FINITURE
FINISHINGS

LACCATA RAL PER ESTERNI EXTERIOR RAL LACQUER	SI / YES
---	----------

IN ACCIAIO INOX STAINLESS STEEL	NO
------------------------------------	----

IN ACCIAIO PRERIVESTITO PRE-COATED STEEL	NO
---	----

TIPOLOGIE DI MONTAGGIO
MOUNTING SOLUTIONS

CON ZANCHE WITH TIES	
-------------------------	---

SU CONTROTELAIO ON SUB-FRAME	
---------------------------------	---

CON TASSELLI WITH BOLTS	
----------------------------	---

SU MAZZETTA ON REVEAL	
--------------------------	---

TAVOLA SINOTTICA
SYNOPTIC TABLE

	NEW IDRA 1B E _i 60 (N05) Pag 28	NEW IDRA 1B E _i 60 (N70) Pag 30	NEW IDRA 2B E _i 60 (N15) Pag 29	NEW IDRA 2B E _i 60 (N71) Pag 31	NEW IDRA 1B E _i 120 (N01) Pag 32	NEW IDRA 1B E _i 120 (N02) Pag 34	NEW IDRA 2B E _i 120 (N10) Pag 33	NEW IDRA 2B E _i 120 (N14) Pag 35	IDRA 1B E _i 30 (T38) Pag 36	IDRA 1B E _i 30 (T39) Pag 37	NEW IDRA 1B FIREWALL E _i 90 (NA7) Pag 44	NEW IDRA 1B E _i 60 SILENT (N47) Pag 38	NEW IDRA 1B E _i 60 SILENT (N48) Pag 39	NEW IDRA 1B SECURITY E _i 120 (ND1) Pag 40	NEW IDRA 1B SECURITY E _i 60 (ND5) Pag 41	NEW IDRA 1B PREMIUM E _i 60 (N60) Pag 42	NEW IDRA 2B PREMIUM E _i 60 (N61) Pag 43
PORTA STANDARD STANDARD DOOR																	
RESISTENZA AL FUOCO FIRE RESISTANCE	E _i 60	E _i 60	E _i 60	E _i 60	E _i 120	E _i 120	E _i 120	E _i 120	E _i 30	E _i 30	E _i 90	E _i 60	E _i 60	E _i 120	E _i 60	E _i 60	E _i 60
TRASMITTANZA TERMICA THERMAL TRANSMITTANCE	W=1,4 W/m²K	W=1,4 W/m²K	W=1,7 W/m²K	W=1,7 W/m²K	W=1,4 W/m²K	W=1,4 W/m²K	W=1,7 W/m²K	W=1,7 W/m²K	W=1,5 W/m²K	W=1,5 W/m²K	W=1,4 W/m²K	W=1,6 W/m²K	W=1,6 W/m²K	W=1,4 W/m²K	W=1,6 W/m²K	W=1,4 W/m²K	W=1,7 W/m²K
ABBATTIMENTO ACUSTICO NOISE REDUCTION	19 dB	19 dB	19 dB	19 dB	19 dB	19 dB	/	/	/	/	19 dB	38 dB	42 dB	19 dB	19 dB	19 dB	19 dB
ANTIEFFRAZIONE BURGLAR RESISTANCE	○	○	○	○	○	○	○	○	○	○	○	○	○	Classe 2	Classe 3	○	○
EXTRA SUPPLEMENTARI EXTRAS																	
KIT FUMI FREDDI (S-1) COLD FUMES KIT (S-1)	●	●	●	●	●	●	●	●	○	○	○	○	○	●	●	●	●
KIT FUMI CALDI (S-5/300) HOT FUMES KIT (S-5/300)	●	●	●	●	●	●	●	●	○	○	○	○	○	●	●	●	●
ABBATTIMENTO ACUSTICO (dB) NOISE REDUCTION (dB)	27 - 34	27 - 34	25 - 30	25 - 30	29 - 35	29 - 35	32 - 36	32 - 36	○	○	27 - 34	/	/	/	/	27 - 34	25 - 30
TENUTA ARIA/VENTO AIR/WIND TIGHTNESS	●	●	●	●	●	●	●	●	○	○	●	○	○	/	/	●	●
FRANCQUICCE/SOPRALUCE SIDE LIGHT/FANLIGHT	●	○	●	○	●	○	●	○	○	○	○	○	○	○	○	○	○
PORTA PER ESTERNI EN 14351-1 EXTERNAL DOOR EN 14351-1	●	●	●	●	●	●	●	●	●	●	●	●	●	●	●	●	●
MONTAGGIO FITTING																	
CON ZANCHE WITH TIES	●	○	●	○	●	○	●	○	●	●	●	●	●	●	○	●	●
SU CONTROTELAIO ON SUB-FRAME	●	○	●	○	●	○	●	○	●	○	●	●	●	●	○	●	●
CON TASSELLI WITH BOLTS	●	○	●	○	●	○	●	○	●	●	●	●	●	●	○	●	●
SU MAZZETTA ON REVEAL	●	○	●	○	●	○	●	○	●	○	●	●	●	●	○	●	●
SU PARETI IN CARTONGESSO ON PLASTERBOARD WALLS	○	●	○	●	○	●	○	●	○	○	○	○	○	○	●	○	○
FINITURA FINISHING																	
FINITURA RAL PER ESTERNI RAL FINISHING FOR EXTERIOR	●	●	●	●	●	●	●	●	●	●	●	●	●	●	●	●	●
IN ACCIAIO INOX STAINLESS STEEL	●	●	●	●	●	●	○	○	○	○	○	●	●	○	○	●	●
IN ACCIAIO PRERIVESTITO PRE-COATED STEEL	●	●	●	●	●	●	●	●	●	●	○	●	●	●	●	●	●
ACCESSORI STANDARD STANDARD ACCESSORIES																	
MANIGLIA+MANIGLIA ANTIFURTO HANDLE+HANDLE ACCIDENT PREVENTION BLACK EPOXY	●	●	●	●	●	●	●	●	●	●	●	●	●	●	○	●	●
MANIGLIA+MANIGLIA CON DEFENDER HANDLE+HANDLE WITH DEFENDER	○	○	○	○	○	○	○	○	○	○	○	○	○	○	●	○	○
SERRATURA A 1 PUNTO DI CHIUSURA 1-LOCKING POINT LOCK	●	●	●	●	●	●	●	●	●	●	●	●	●	○	○	●	●
SERRATURA A 3 PUNTI DI CHIUSURA 3-LOCKING POINT LOCK	○	○	○	○	○	○	○	○	○	○	○	○	○	●	●	○	○
CERNIERA A VISTA EXPOSED HINGE	●	●	●	●	●	●	●	●	●	●	○	●	●	●	●	○	○
CERNIERA NASCOSTA CONCEALED HINGE	○	○	○	○	○	○	○	○	○	○	●	○	○	○	○	○	○
CERNIERA A 3 ALI 3-FLAP HINGE	○	○	○	○	○	○	○	○	○	○	○	○	○	○	○	●	●
EXTRA SUPPLEMENTARI ADDITIONAL EXTRAS																	
FINISTRATURA RETTANGOLARE ORLO RECTANGULAR WINDOW ROUND WINDOW	●	●	●	●	●	●	●	●	●	●	●	○	○	○	○	●	●
FASCIA/ZOCCOLO PARACOLPI BUNKER BAND/SKIRTING	●	●	●	●	●	●	●	●	●	●	●	●	●	●	●	●	●
CERNIERA A 3 ALI 3-FLAP HINGE	●	●	●	●	●	●	□	□	○	○	○	○	○	○	○	○	○
MANIGLIERIA ANTIPANICO PANIC EXIT BAR	●	●	●	●	●	●	●	●	●	●	●	●	●	●	●	●	●
SERRATURA A 3 PUNTI DI CHIUSURA 3-LOCKING POINT LOCK	●	●	●	●	●	●	●	●	○	○	●	●	●	○	○	●	●
MANIGLIERIA CONFORME ALLE NORME DIN DIN COMPLIANT HANDLES	●	●	●	●	●	●	●	●	○	○	●	●	●	●	○	●	●
CONTROLLO ACCESSI ACCESS MONITORING																	
SBLOCCO ELETTRICO ELECTRIC UNLOCK	●	●	●	●	●	●	●	●	●	●	●	●	●	○	○	●	●
ELETTROMANIGLIA ELECTROHANDLE	●	●	●	●	●	●	●	●	●	●	●	●	●	○	○	●	●
SERRATURA ELETTRICA ELECTRIC LOCK	●	●	●	●	●	●	●	●	●	●	●	●	●	○	○	●	●
ELETTROMAGNETI ELECTROMAGNETS	●	●	●	●	●	●	●	●	●	●	●	●	●	●	●	●	●
ELETTROBLOCCHI MAGNETICI MAGNETIC ELECTRIC BLOCKS	●	●	●	●	●	●	●	●	●	●	●	●	●	●	●	●	●
DIMENSIONI CERTIFICATE* CERTIFIED DIMENSIONS																	
LARGHEZZA (LVM) WIDTH (LVM)	675 1350	675 1350	950 2600	1150 2300	675 1350	675 1350	950 2600	1150 2300	500 1350	520 1140	675 1350	750 1350	750 1350	800 1100	800 1100	675 1100	950 2600
ALTEZZA (HVM) HEIGHT (HVM)	1987 2650	1987 2650	1987 2650	1987 2650	1987 2650	1987 2650	1987 2650	1987 2650	1750 2645	1730 2640	1987 2300	2000 2650	2000 2650	1987 2365	1987 2365	1987 2650	1987 2650

* Per la disponibilità nella propria nazione, chiedere al ns ufficio tecnico
* Ask our technical assistance office for availability in your country

- DISPONIBILE - AVAILABLE
- NON DISPONIBILE - NOT AVAILABLE
- DISPONIBILE SOLO PER PORTE CERTIFICATE PER ESTERNI EN 14351-1
ONLY FOR EN 14351-1 CERTIFIED EXTERIOR DOORS

- DISPONIBILE - AVAILABLE
- NON DISPONIBILE - NOT AVAILABLE



REFERENZE

Permedica Spa - Merate (LC)

1-2

CampZero Active Luxury Resort - Champoluc (AO)

3-4-5-6



DIERRE S.p.A
Strada Statale per Chieri, 66/15
14019 Villanova d'Asti (AT)
Tel.39/0141.94.94.11
E-mail: info@dierre.it

www.dierre.com